

Visit us at www.magnumaustralia.com

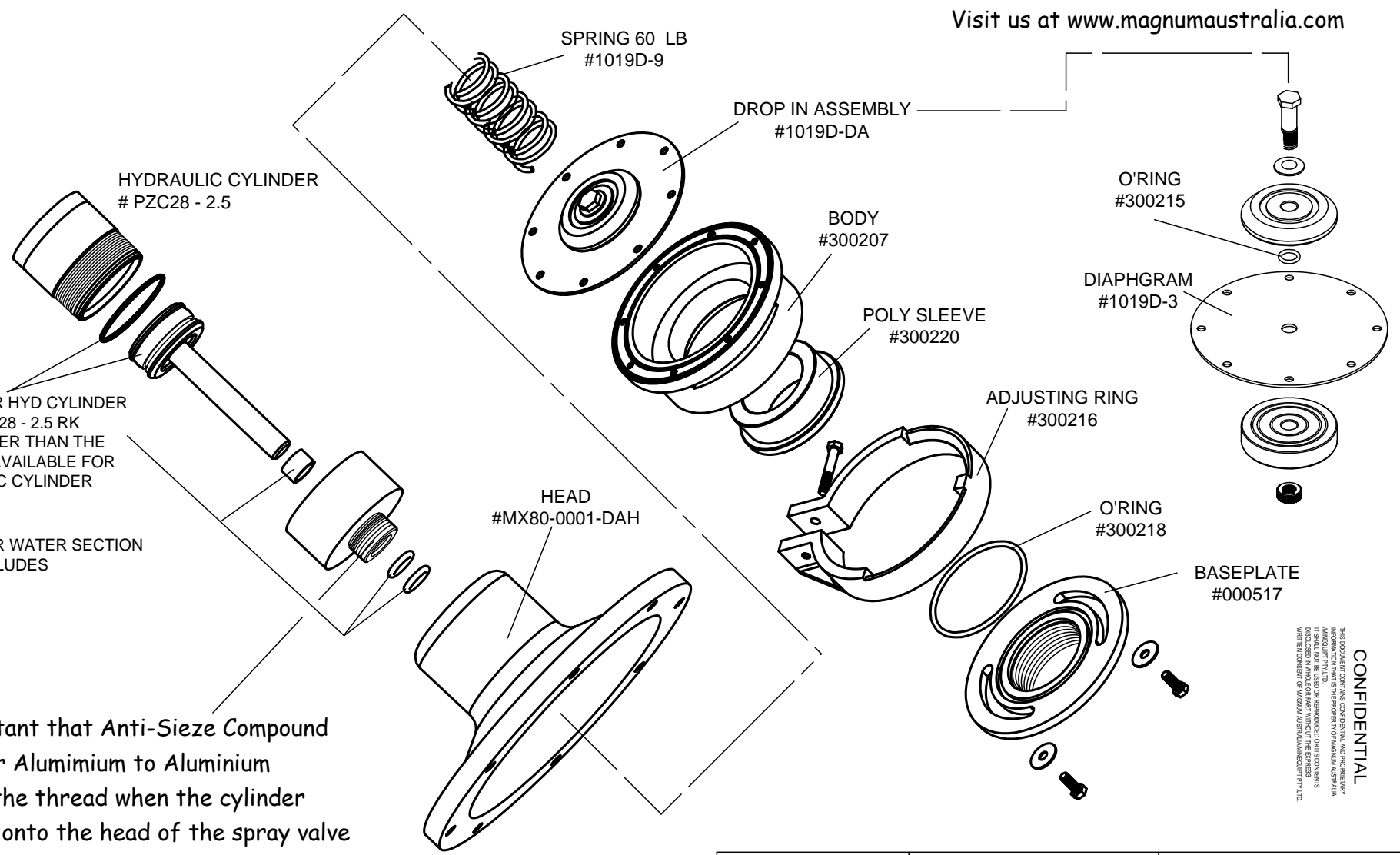

RECON KIT FOR HYD CYLINDER
SEAL KIT # PZC28 - 2.5 RK
NO PARTS OTHER THAN THE
SEAL KIT ARE AVAILABLE FOR
THE HYDRAULIC CYLINDER

RECON KIT FOR WATER SECTION
#1019D-RK INCLUDES
1 x 1019D-DA
1 x 300220
2 x 1019D-3

It is important that Anti-Sieze Compound
suitable for Alumimium to Aluminium
is used on the thread when the cylinder
is mounted onto the head of the spray valve

CONFIDENTIAL
 THIS DOCUMENT CONTAINS CONFIDENTIAL AND PROPRIETARY INFORMATION THAT IS THE PROPERTY OF MAGNUM AUSTRALIA. IT SHALL NOT BE REPRODUCED OR DISCLOSED IN WHOLE OR IN PART WITHOUT THE EXPRESS WRITTEN CONSENT OF MAGNUM AUSTRALIA (PVT) LTD.

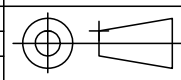
ISSUE				REVISION				DRAWN	DATE	APPD.	EXCEPT WHERE NOTED ALL DIMENSIONS IN MILLIMETRES	 MAGNUM AUSTRALIA	DRAWN TO AS 1100		SURFACE FINISH	MATERIAL :
DRAWINGS SUBJECT TO FINAL DESIGN UNLESS CONFIRMED										SHEET SIZE: A4			TOLERANCES UNLESS NOTED		SCALE	35 PARKHURST DRIVE, KNOXFIELD, VICTORIA 3180 PHONE (03) 9801 8433 FAX (03) 9800 3240 Contact us on tanks@magnumaustralia.com
CONFIRMED BY: SIGNATURE: _____ DATE: _____												WHOLE DIMENSIONS	±0.50	DRAWN	NML	
										ONE DECIMAL PLACE		±0.25	DATE	13/10/2011	SHEET 1 OF 1 SHEETS	
										TWO DECIMAL PLACES	±0.10	CHECKED		DRG. No. 1019 - DA - H - MK2		
										ANGLES	±30'	DATE				