

Maxi Spray Valve Hydraulic Operated

- SINGLE ACTING 1019 – SA – H – MK2 (AUST)
- MX80 – SA - H – MK2 (USA)

- Weighs 9 kilograms (20lbs)
- Compact design and shape for fast and easy installation - see dimensions
- Manufactured from marine grade alloy
- Low maintenance polymer inserts control the water valve operation
- Fits to any existing piping configuration from 80mm (3") nominal bore
- Eliminates the need for additional water control valves (ball, butterfly, knife)
- Supplies a flat, dense and variable spray pattern
- Provides an even fan spray throughout the entire spray pattern
- Manually adjustable spray pattern via a fitted adjustable ring
- Can control output water flow from 0 - 1350 l/min (approx)
- Up to 12 metre distance spray throw
- Up to 11 metre spray width
- 360° adjustable swivel rotation can be fitted
- 3" BSP F threaded baseplate to accept any preferred quick release mounting
- 0 - 90° manually controlled fan width spray setting
- S/steel spring and fasteners
- Water pressure opens the valve
- Hydraulic pressure controls closing of the valve
- Spring pressure keeps valve closed when hydraulic pressure not present and pump not operating
- Can use electric or RF cabin switching to control valve operation
- Valves are fully pressure tested prior to packaging
- Serial numbered and engraved with unique identification for traceability
- Full warranty on parts
- Spare parts readily available
- Fully serviceable
- Operating Hydraulic Pressure must be limited to 40 bar (600 PSI)

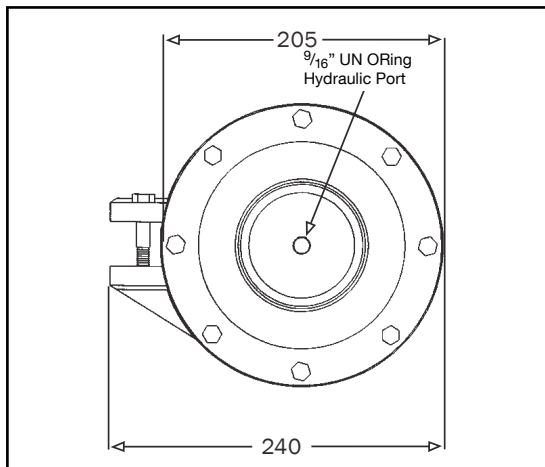

maxi spray valve – single acting

1019 – SA – H – MK2 (AUST)
MX80 – SA – H – MK2 (USA)