



Hydraulic Water Cannon RM50-H

Index

1. Water Cannon – Warning – Hazard to Health	P.2
2. RM50-H Brochure	P.3-4
3. Outline Drawing of Cannon (Exploded View / Spare Parts)	P.5-10
4. Installation Instructions	P.11
5. Maintenance Schedule	P.12
6. Hydraulic Schematic & Hydraulic Information	P.13-19
7. Electric Schematic & Electrical Information	P.20-25



1. Water Cannon - Warning - Hazard to Health

Care needs to be taken operating a water cannon. Water from a cannon is capable of inflicting serious injury to a person in the path of the jet.

Primary injuries would be those from the direct hit to the body by the impact of the jet. These would include bruising of internal organs and damage to the eyes.

Secondary injuries can occur as a result of the acceleration of the body in collision with hard surfaces. These injuries would be largely skeletal, such as broken bone. Other injuries could be caused by debris, accelerated by the force of the water jet striking the person.

The following should be considered as a minimum level of care required when operating a water cannon:

- Know the direction that the cannon is aiming at. Aim the cannon in a safe direction before turning the water on.
- Keep all personal out of the front of the cannon. Dangerous flow velocities can cause serious injury for quite a distance in front of the cannon.
- The cannon contain moving parts. Keep hands, fingers, and objects away from pinch points when working close to the cannon.
- Do not attempt to modify the equipment in any way. Modifications of the equipment may result in damage and/or malfunction of the equipment which could cause injury to the operator or other. Also, the manufacturer's warranty will be void.
- Follow all the maintenance procedures in the documentation. Failure to do so, can result in damage and/or malfunction of the equipment which could cause injury to the operator or other.



2. RM65-H Brochure

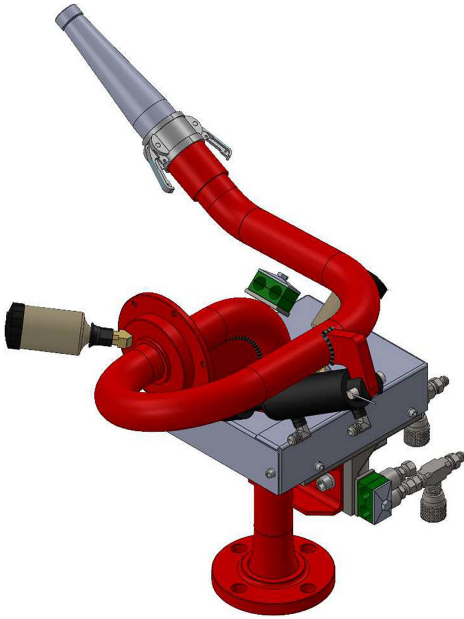

- Easy installation
- Pressure tested to 3000 Kpa
- 50mm (2") ANSI 150lb flanged inlet connection
- Hydraulic slew and elevation control
- Electric joystick cabin control supplied as standard
- Optional radio frequency (R.F.) wireless control available
- Full automation via sequencing or PLC technology
- Can be retro-fitted as optional
- Engineered balanced and compact design
- Direct gear drive offering up to 360° precision slew operation
- Hydraulic cylinder controlling 60° angle elevation
- Designed for mobile or fixed mounted applications
- Optional "power pack" system or can control via vehicle hydraulics
- Patented "non-flog" Magnum Australia swivel bearings
- Automatic grease lubrication fitted
- Director nozzle supplied as standard; 16mm (5/8") orifice and 30m of water throw at 7 bar
- All stainless steel fasteners and protective guards fitted
- Fully serviceable



8 7 6 5 4 3 2 1

F

F

E

E

D

D

C

C

B

B

A

A

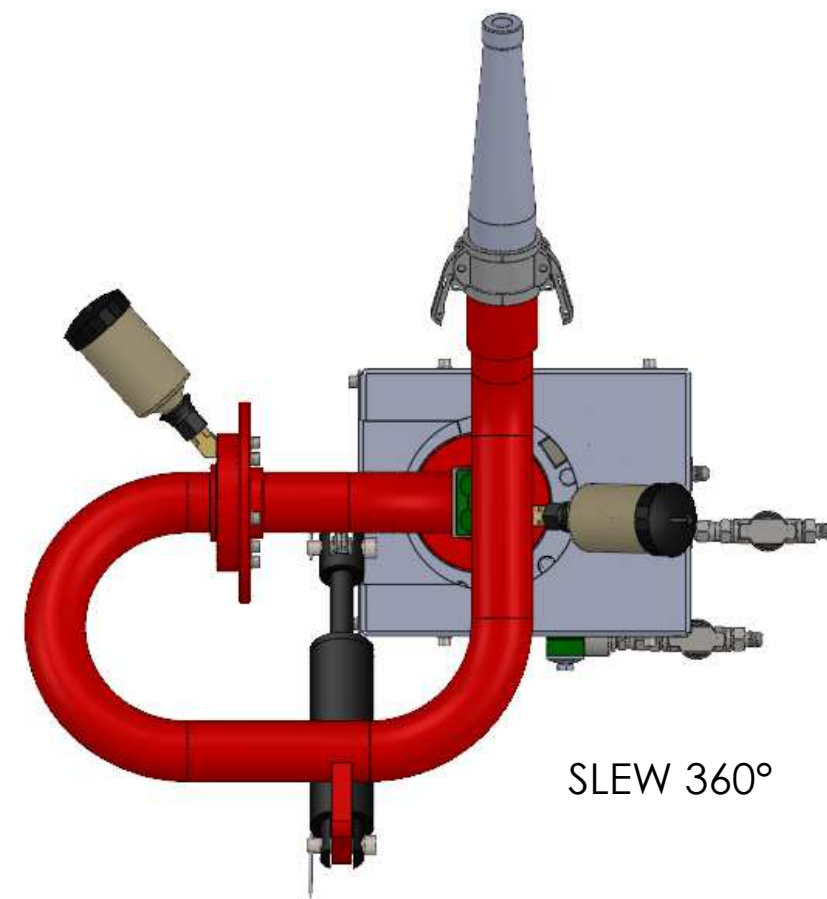
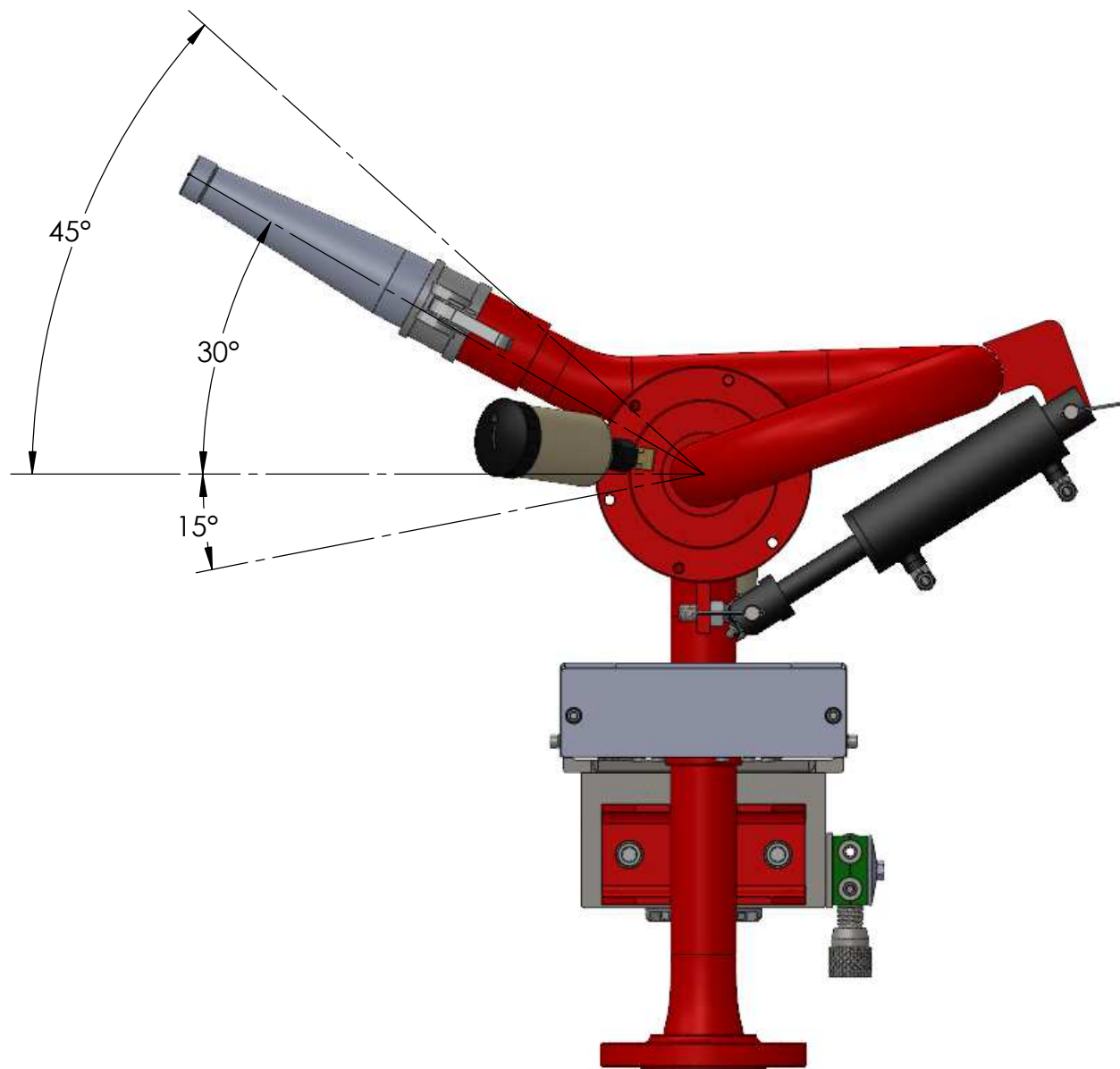

UNLESS OTHERWISE SPECIFIED DIMENSIONS ARE IN MILLIMETERS SURFACE FINISH: PAINT:		TOLERANCES ACCORDING TO ISO 2768		DO NOT SCALE DRAWING	DEBURR AND BREAK SHARP EDGES
				 MAGNUM AUSTRALIA 35 PARKHURST DRIVE KNOXFIELD, VICTORIA 3180 PHONE 98018433	
	NAME	SIGNATURE	DATE	REVISION	TITLE: WATER CANNON RM50-H ANGLES
DRAWN	Alberto C		15/12/2020		
CHECKED					
APPROVED					
			MATERIAL:	DWG NO.	
			N/A	RM50-H	
			THICKNESS: N/A	SCALE: 1:4	SHEET 1 OF 1

8 7 6 5 4 3 2 1 P.4



3. Outline Drawing of Cannon & Exploded View / Spare Parts

8 | 7 | 6 | 5 | 4 | 3 | 2 | 1

F
E
D
C
B
A

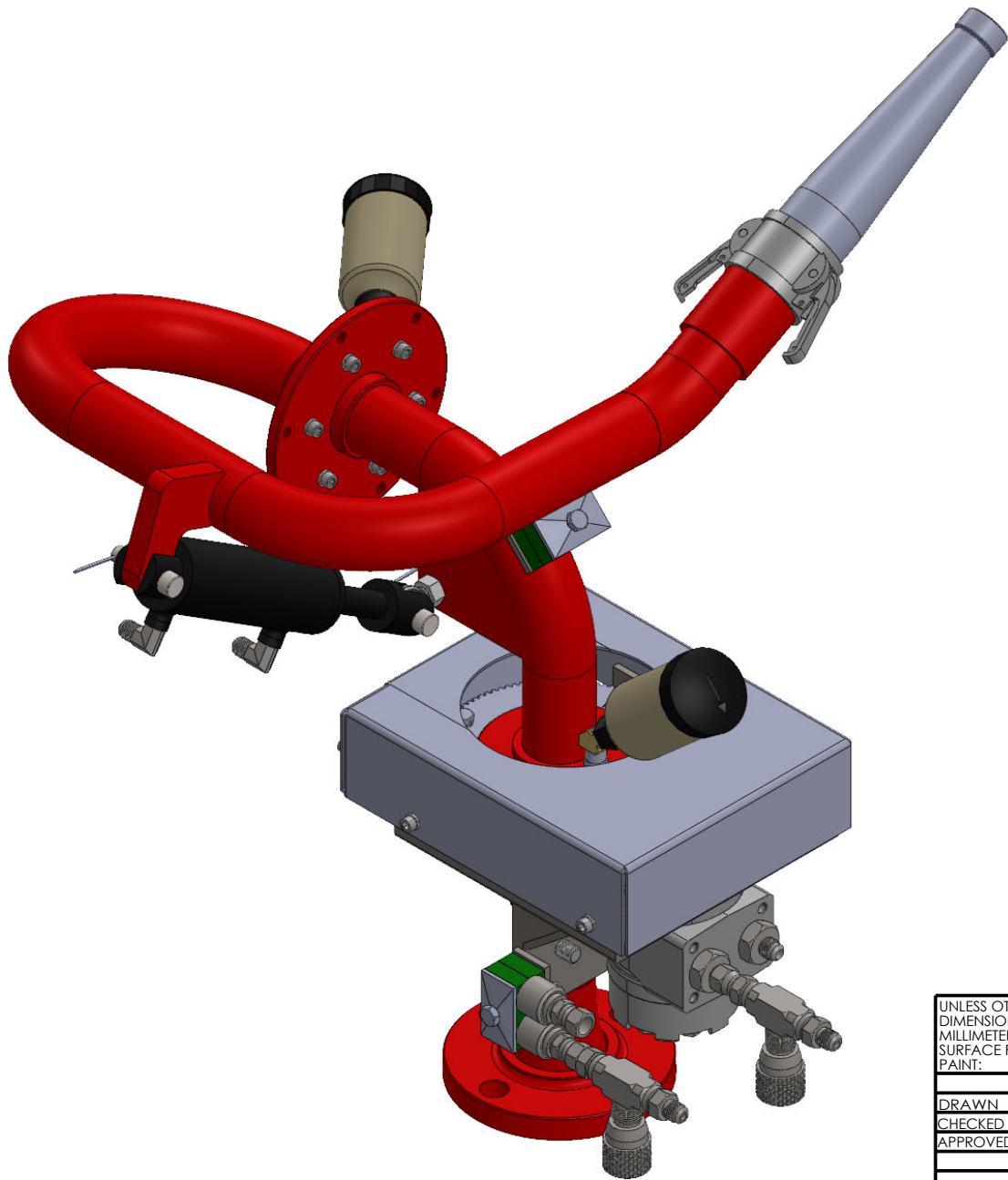

8 | 7 | 6 | 5 | 4 | 3 | 2 | 1

UNLESS OTHERWISE SPECIFIED DIMENSIONS ARE IN MILLIMETERS		TOLERANCES UNLESS NOTED WHOLE DIMENSIONS ±0.50 ONE DECIMAL PLACE ±0.25 TWO DECIMAL PLACES ±0.10 ANGLES ±0.30°		DO NOT SCALE DRAWING	DEBURR AND BREAK SHARP EDGES
SURFACE FINISH: PAINT:				 MAGNUM AUSTRALIA <small>35 PARKHURST DRIVE KNOXFELD, VICTORIA 3180 PHONE 98018433</small>	
	NAME	SIGNATURE	DATE	REVISION	TITLE:
DRAWN	Alberto C		15/12/2020		WATER CANNON RM50-H
CHECKED					
APPROVED					
					DWG NO.
					RM50-H
					A3
					THICKNESS: N/A
					SCALE: 1:3
					SHEET 1 OF 5

8 7 6 5 4 3 2 1

F
E
D
C
B
A

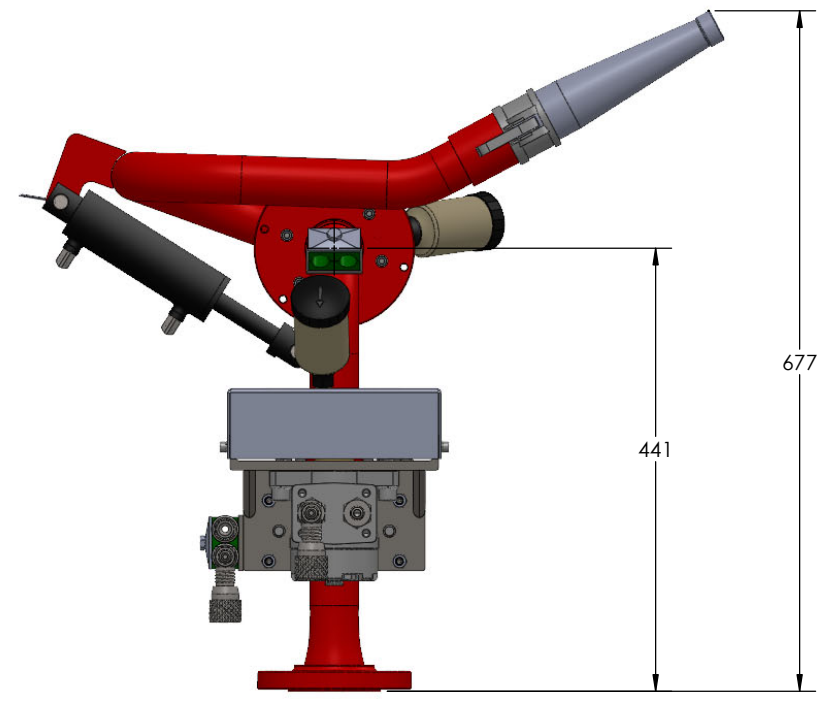
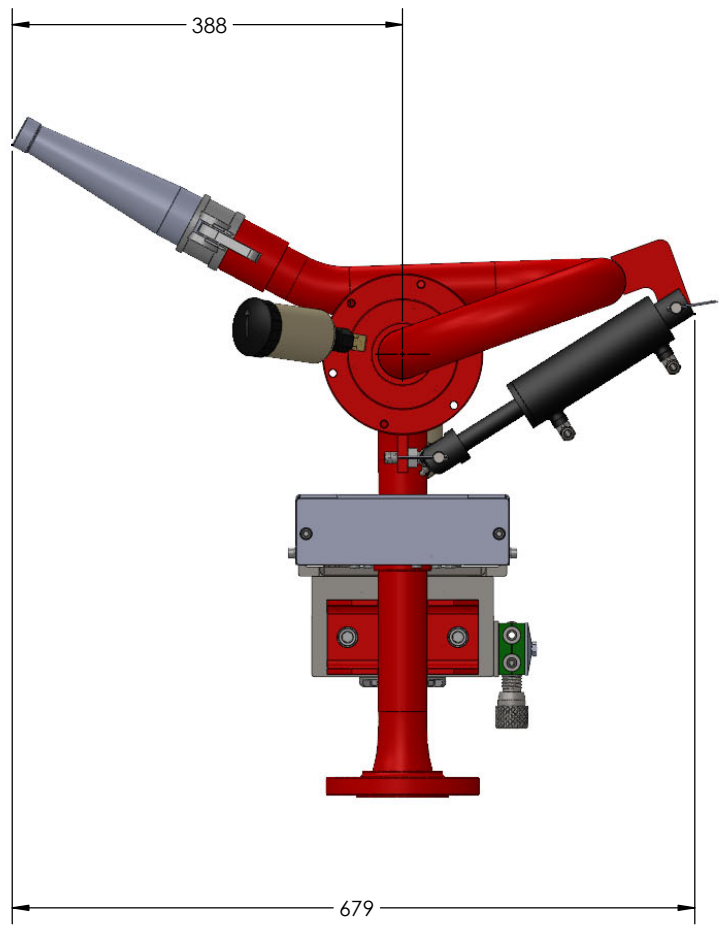

8 7 6 5 4 3 2 1 P.7

UNLESS OTHERWISE SPECIFIED DIMENSIONS ARE IN MILLIMETERS SURFACE FINISH: PAINT:		TOLERANCES UNLESS NOTED WHOLE DIMENSIONS ±0.50 ONE DECIMAL PLACE ±0.25 TWO DECIMAL PLACES ±0.10 ANGLES ±0.30°		DO NOT SCALE DRAWING	DEBURR AND BREAK SHARP EDGES
				 MAGNUM AUSTRALIA <small>35 PARKHURST DRIVE KNOXFELD, VICTORIA 3180 PHONE 28018433</small>	
	NAME	SIGNATURE	DATE	REVISION	TITLE:
DRAWN	Alberto C		15/12/2020		WATER CANNON RM50-H
CHECKED					
APPROVED					
					DWG NO.
					RM50-H
					MATERIAL:
					N/A
					THICKNESS: N/A
					SCALE: 1:5
					SHEET 2 OF 5

A3

P.7

8 7 6 5 4 3 2 1

F

F

E

E

D

D

C

C

B

B

A

A

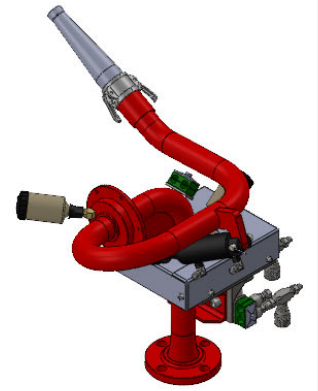
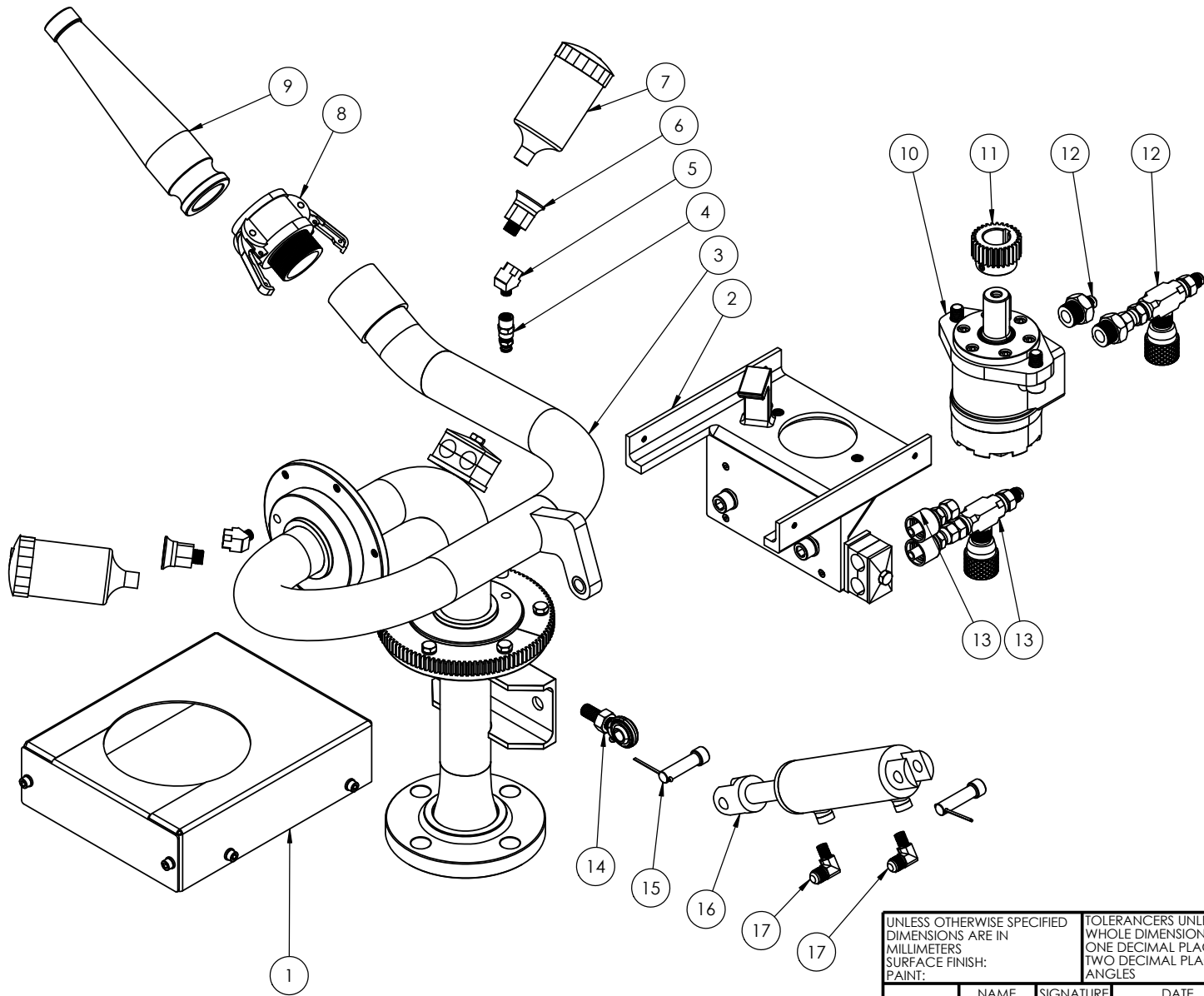



UNLESS OTHERWISE SPECIFIED DIMENSIONS ARE IN MILLIMETERS SURFACE FINISH: PAINT:		TOLERANCES UNLESS NOTED WHOLE DIMENSIONS ±0.50 ONE DECIMAL PLACE ±0.25 TWO DECIMAL PLACES ±0.10 ANGLES ±0.30°		DO NOT SCALE DRAWING	DEBURR AND BREAK SHARP EDGES
					MAGNUM AUSTRALIA 35 PARKHURST DRIVE KNOXFELD, VICTORIA 3180 PHONE 98018433
DRAWN	NAME	SIGNATURE	DATE	REVISION	TITLE:
CHECKED	Alberto C		15/12/2020		WATER CANNON RM50-H
APPROVED	Rocky		15/12/2020		
				MATERIAL:	DWG NO.
				N/A	RM50-H
				THICKNESS: N/A	SCALE: 1:4
					SHEET 3 OF 5

8 7 6 5 4 3 2 1 P.8

8 | 7 | 6 | 5 | 4 | 3 | 2 | 1

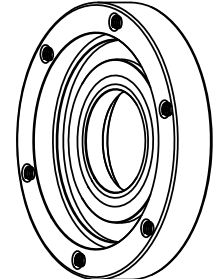
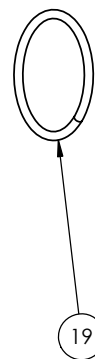
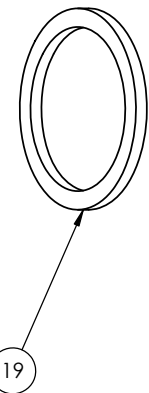
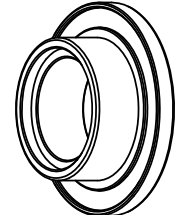
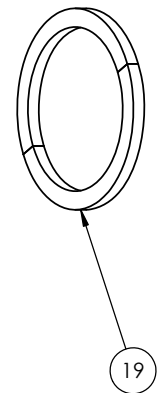
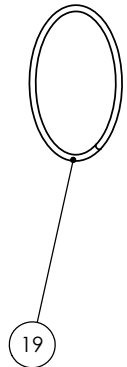
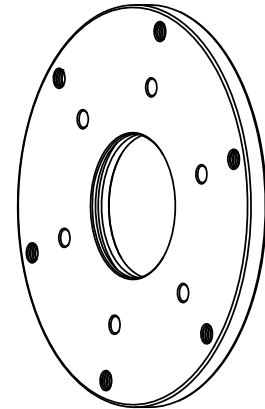
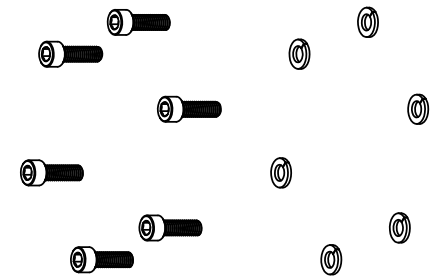
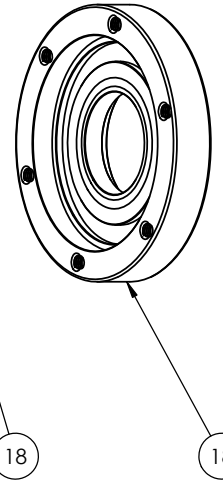
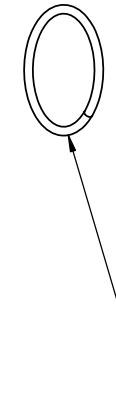
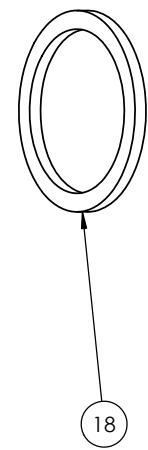
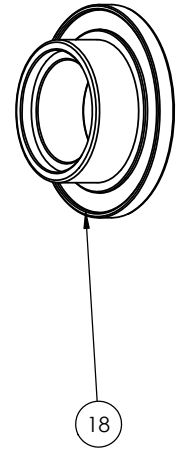
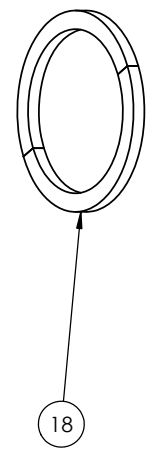
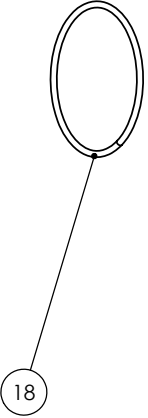
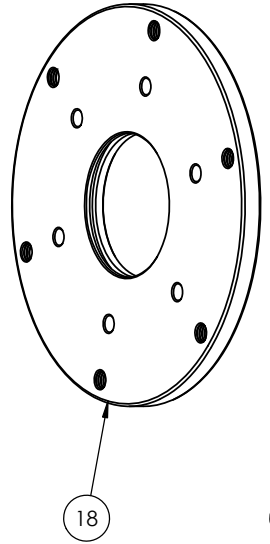
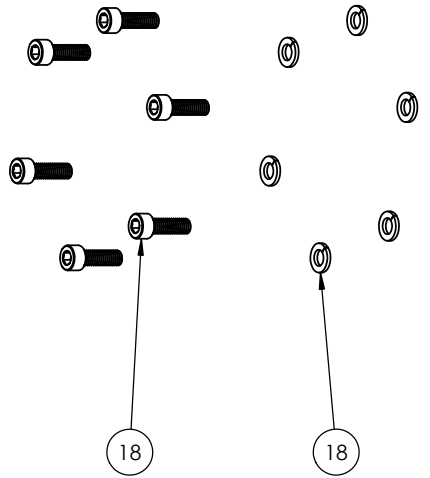
F
E
D
C
B
A



UNLESS OTHERWISE SPECIFIED DIMENSIONS ARE IN MILLIMETERS SURFACE FINISH: PAINT:		TOLERANCES UNLESS NOTED WHOLE DIMENSIONS ±0.50 ONE DECIMAL PLACE ±0.25 TWO DECIMAL PLACES ±0.10 ANGLES ±0.30°		DO NOT SCALE DRAWING		DEBURR AND BREAK SHARP EDGES																		
				 MAGNUM AUSTRALIA 35 PARKHURST DRIVE KNOXFELD, VICTORIA 3180 PHONE 28018433		COMPLETE BEARING FOR RM50-H																		
<table border="1"> <thead> <tr> <th></th> <th>NAME</th> <th>SIGNATURE</th> <th>DATE</th> <th>REVISION</th> </tr> </thead> <tbody> <tr> <td>DRAWN</td> <td>Alberto C</td> <td></td> <td>15/12/2020</td> <td></td> </tr> <tr> <td>CHECKED</td> <td>Rocky</td> <td></td> <td>15/12/2020</td> <td></td> </tr> <tr> <td>APPROVED</td> <td></td> <td></td> <td></td> <td></td> </tr> </tbody> </table>		NAME	SIGNATURE					DATE	REVISION	DRAWN	Alberto C		15/12/2020		CHECKED	Rocky		15/12/2020		APPROVED				
	NAME	SIGNATURE	DATE	REVISION																				
DRAWN	Alberto C		15/12/2020																					
CHECKED	Rocky		15/12/2020																					
APPROVED																								
		MATERIAL: N/A		MM40-4005		A3																		
		THICKNESS: N/A		SCALE: 1:2		SHEET 4 OF 5																		

8 | 7 | 6 | 5 | 4 | 3 | 2 | 1 | P.9

8 | 7 | 6 | 5 | 4 | 3 | 2 | 1

ITEM NO.	PART NUMBER	DESCRIPTION	QTY.
1	HRM-GUARD-AS	MOTOR GUARD COVER	1
2	HRM-0024A-AS	HYDRAULIC MOTOR MOUNT RM50-H	1
3	RM50-H	RM50-H BARE CANNON	1
4	2525-1-8-36	STRAIGHT GREASE FITTING 1/8	1
5	P-1-8451-4	90° GREASE ELBOW 1/8	2
6	A620PFLEX	PERMALUBLE SUPPORT FLANGE	2
7	BM0007	GREASE CAPSULE	2
8	CAMLOCK02	TYPE B CAMLOCK	1
9	MM40-0015	5/8 ORIFICE DIRECTOR NOZZLE	1
10	HRM-M60610-AS	MOTOR FOR RM50-H	1
11	HRM0026-AS	GEAR FOR MOTOR	1
12	S90-0914-AS	JIC NIPPLE	1
13	C12A2S106060-AS	JIC STRAIGHT FITTING	1
14	RM0025-AS	M12 ROD END	1
15	RM0028-H-AS	CLEVIS PIN	2
16	HYDCYL07	HYDRAULIC CYLINDER	1
17	R1A25M907M-0602-AS	1/8 BSP - 9/16 JIC	1
18	MM40-4005	COMPLETE BEARING FOR RM50-H	2
19	MM40-RK2	BEARING RECONDITIONING KIT FOR RM50-H	2

UNLESS OTHERWISE SPECIFIED DIMENSIONS ARE IN MILLIMETERS		TOLERANCES UNLESS NOTED WHOLE DIMENSIONS ±0.50 ONE DECIMAL PLACE ±0.25 TWO DECIMAL PLACES ±0.10 ANGLES ±0.30°		DO NOT SCALE DRAWING	DEBURR AND BREAK SHARP EDGES
SURFACE FINISH: PAINT:				 MAGNUM AUSTRALIA <small>35 PARKHURST DRIVE KNOXFELD, VICTORIA 3180 PHONE 28018433</small>	
	NAME	SIGNATURE	DATE	REVISION	TITLE:
DRAWN	Alberto C		15/12/2020		WATER CANNON RM50-H
CHECKED	Rocky		15/12/2020		
APPROVED					
					DWG NO.
					RM50-H
					A3
					MATERIAL: N/A
					THICKNESS: N/A
					SCALE: N/A
					SHEET 5 OF 5

8 | 7 | 6 | 5 | 4 | 3 | 2 | 1



4. Installation Instructions

1. Weld the flange supplied in the kit to the water cannon supply pipe.
2. Mount the cannon (monitor) and water on / off valve onto the flange using bolts and nuts supplied in the kit. Stabilisers and gussets may be required to ensure that the mounting is secure and rigid. The water on /off valve should be located between the flanges of the water cannon and the mounting flange welded to supply piping. Ensure the monitor is correctly mounted so it CANNOT direct water at the cabin of the vehicle.
3. Activate the Auto Lube grease capsule located on the Monitor Bearings to 12-month grease injection setting.
4. Screw the nozzle to the threaded end of the water cannon. Director Nozzle is standard supply. Foam induction Fog Nozzle (RFIN) is available as an option.
5. Mount the Joystick Cabin Controller Box (electric) in a position that is ergonomic for operator to use.
6. Mount the hydraulic valve manifold in a desired position (external to vehicle cabin). Note: Generally mounted close to the water cannon monitor to allow for short length of hydraulic hoses between the manifold and the cannon.
7. Run the electrical cable 8 m supplied as standard (optional extension cable is available if required) from the cabin control box to the main control box. Cut the cable to the desired length and connect up the plugs.
8. Connect the cable from the Main Control Box to the hydraulic valves on the manifold. Cut the cable to the desired length allowing for neat installation of the wiring to the solenoids. Connect the electrical cables to the solenoid valves using the Hirschmann Plugs supplied and the electric schematic diagram. Ensure all plugs are properly sealed against moisture ingress.
9. Connect the power wire as per the electric schematic.
10. Ensure the hydraulic pressure reducing valve is fitted into the hydraulic system circuit (refer to the system hydraulic circuit).
11. Connect the hydraulic hoses from supply oil to hydraulic valve manifold using 3/8 hoses. See the hydraulic schematic.
12. Connect the hydraulic hoses from hydraulic valve manifold to the return on the tank. See the hydraulic schematic.
13. Connect the required hydraulic hoses as per the hydraulic schematic from the hydraulic manifold to the water cannon. 2 hoses are required for each function.
14. Your Remote Control Water Cannon is now ready for operations.
15. Turn on the vehicle power and air to the unit.
16. Check that all air fittings are correctly fitted and there are no air leaks evident.
17. Check that all hydraulic hoses and fittings are correctly installed and no hydraulic leaks are evident.
18. Check all bolts are securely tightened and no water leaks are evident.
19. Now test the unit with the water pump operating and passing water through the nozzle.
20. Monitor slew and elevation speed can be adjusted to suit your desired operating speed. The speed adjusters (hydraulic needle valves) are located on the piston end of each hydraulic cylinder fitted to the water cannon. Screw them clockwise (in) to slow the unit, or anti-clockwise (out) to increase the speed of operation.
21. A comprehensive parts book has been supplied for your service assistance.



5. Maintenance Schedule

Initial Service

1. The upper and lower bearings have been filled with Multi-Purpose EP Type Grease in the factory at the time of assembly. 4 pumps of grease from a grease gun should be sufficient if a new bearing has been installed.
2. Set the automatic lubrication canister supplied with the cannon to 12 months. This activates the lubricator.
3. Lubricate the rod ends (mounting for cylinders) using Multi-Purpose EP Type Grease. 1 pump of grease from a grease gun should be sufficient.
4. Smear the gears with grease equivalent to Molybond Opal Pin & Bush.
5. Check the operation of the water cannon; slew and elevation.

Quarterly Service

1. Check the condition of the swivel bearings by holding the pipe firmly and shaking it vigorously. There should be no play in the swivel bearing. Replace the seals and wear rings in the swivel bearings if there is any play.
2. Check the waster cannon for leaks. If there is a leak, it will occur at the swivel bearings. Replace the seals and wear rings in the swivel bearings if there is a leak on the water cannon.
3. Lubricate the rod ends (mounting for cylinders) using Multi-Purpose EP Type Grease. 1 pump of grease from a grease gun should be sufficient.
4. Check the automatic lubrication canister. The canister has been initially set up for 12 months. If the ambient temperature is above 40 degrees centigrade, the life of the canister may be reduced. Replace the canister if there is no sign of grease in it. Set the automatic lubrication canister to 12 months. This activates the lubricator.
5. Smear the gears with grease equivalent to Molybond Opal Pin & Bush.
6. Check the operation of the water cannon; slew and elevation.

Annual Service

1. Strip and inspect the swivel bearing on the cannon. Replace the wear rings and the seals.
2. Install a new automatic lubrication canister as is indicated in quarterly service.



6. Hydraulic Schematic & Hydraulic Information

**STANDARD NOZZLE MANIFOLD
(HYDRAULIC BUTTERFLY)**

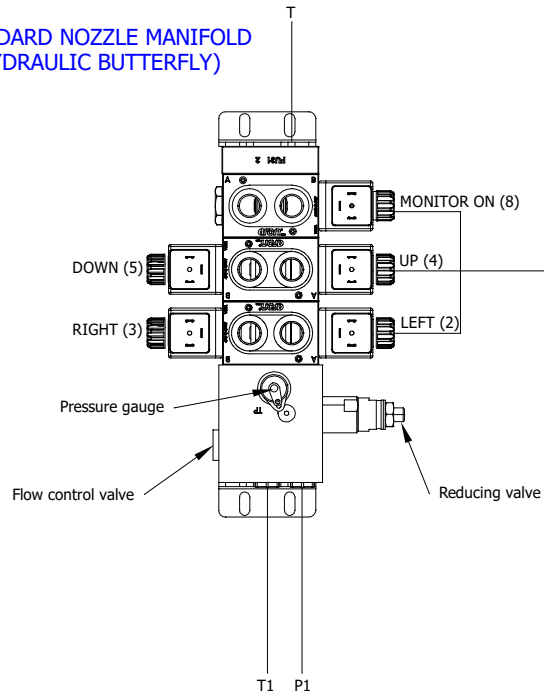

Actual hydraulic manifold will change based on configuration purchased.
(Ports on manifold are 3/8" BSPP)

Hydraulic hoses between valves and actuators required to be installed
(hydraulic hoses and fittings are not supplied)

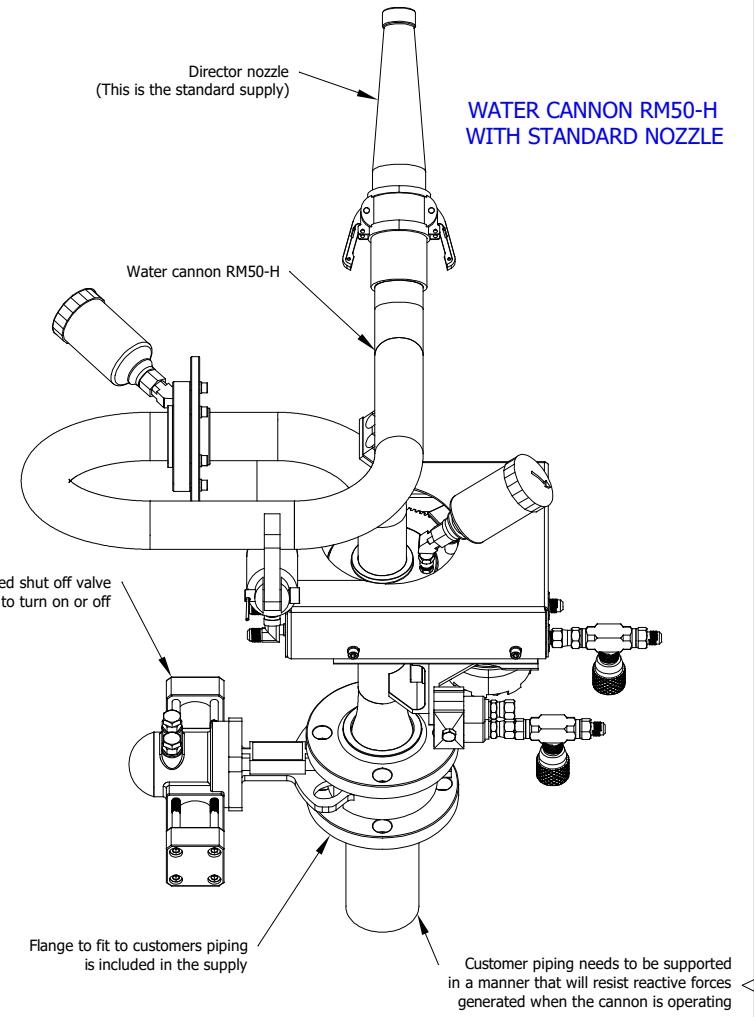
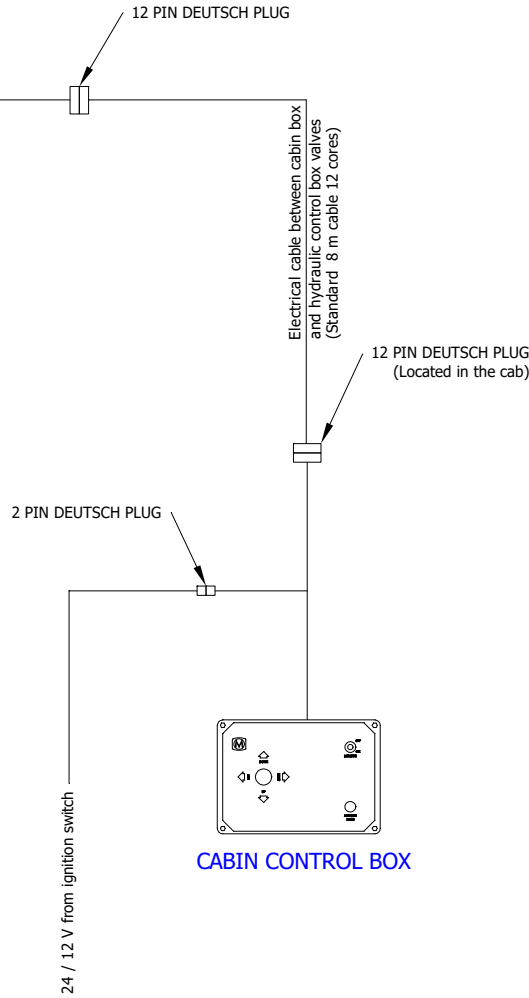

Hydraulic hoses between valves and cylinders required to be installed
(hydraulic hoses and fittings are not included in supply)

**RM50-H
STANDARD NOZZLE CONFIGURATION
HYDRAULIC BUTTERFLY**

				REVISION
				0
0	15/12/2020	AlbertoC		
REV.	DATE	NAME	CHANGES	SCHEME
				01
User data 1			User data 2	

CONTRACT:

LOCATION: **+L1 Main electrical closet**

**STANDARD NOZZLE MANIFOLD
(AIR BUTTERFLY)**

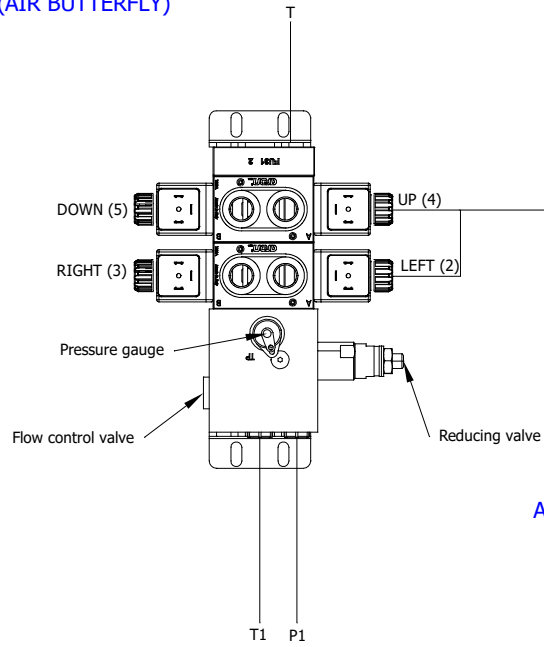

AIR BUTTERFLY

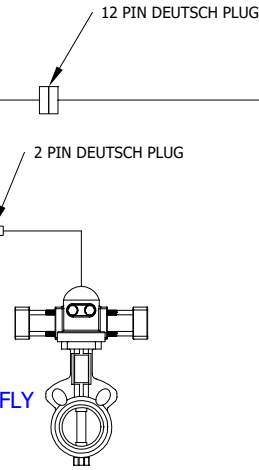

Electrical cable between cabin box and hydraulic control box valves (Standard 8 m cable 12 cores)

12 PIN DEUTSCH PLUG (Located in the cab)

2 PIN DEUTSCH PLUG

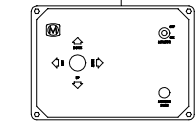

CABIN CONTROL BOX

Actual hydraulic manifold will change based on configuration purchased. (Ports on manifold are 3/8" BSPP)

Hydraulic hoses between valves and actuators required to be installed (hydraulic hoses and fittings are not supplied)

24 / 12 V from ignition switch

WATER CANNON RM50-H WITH STANDARD NOZZLE

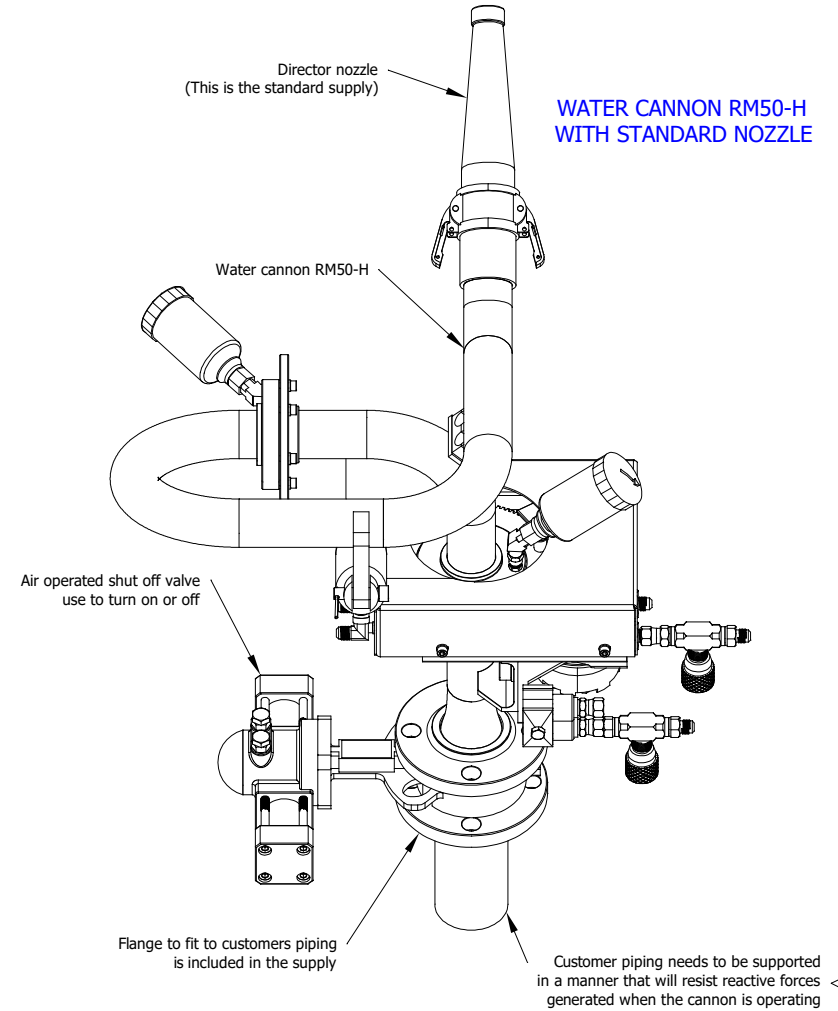

Hydraulic hoses between valves and cylinders required to be installed (hydraulic hoses and fittings are not included in supply)

CONTRACT:	LOCATION: +L1	Main electrical closet	RM50-H		REVISION 0			
			STANDARD NOZZLE CONFIGURATION			SCHEME 02		
			AIR BUTTERFLY					
			REV.	DATE	NAME	CHANGES	User data 1	User data 2
			0	15/12/2020	AlbertoC			

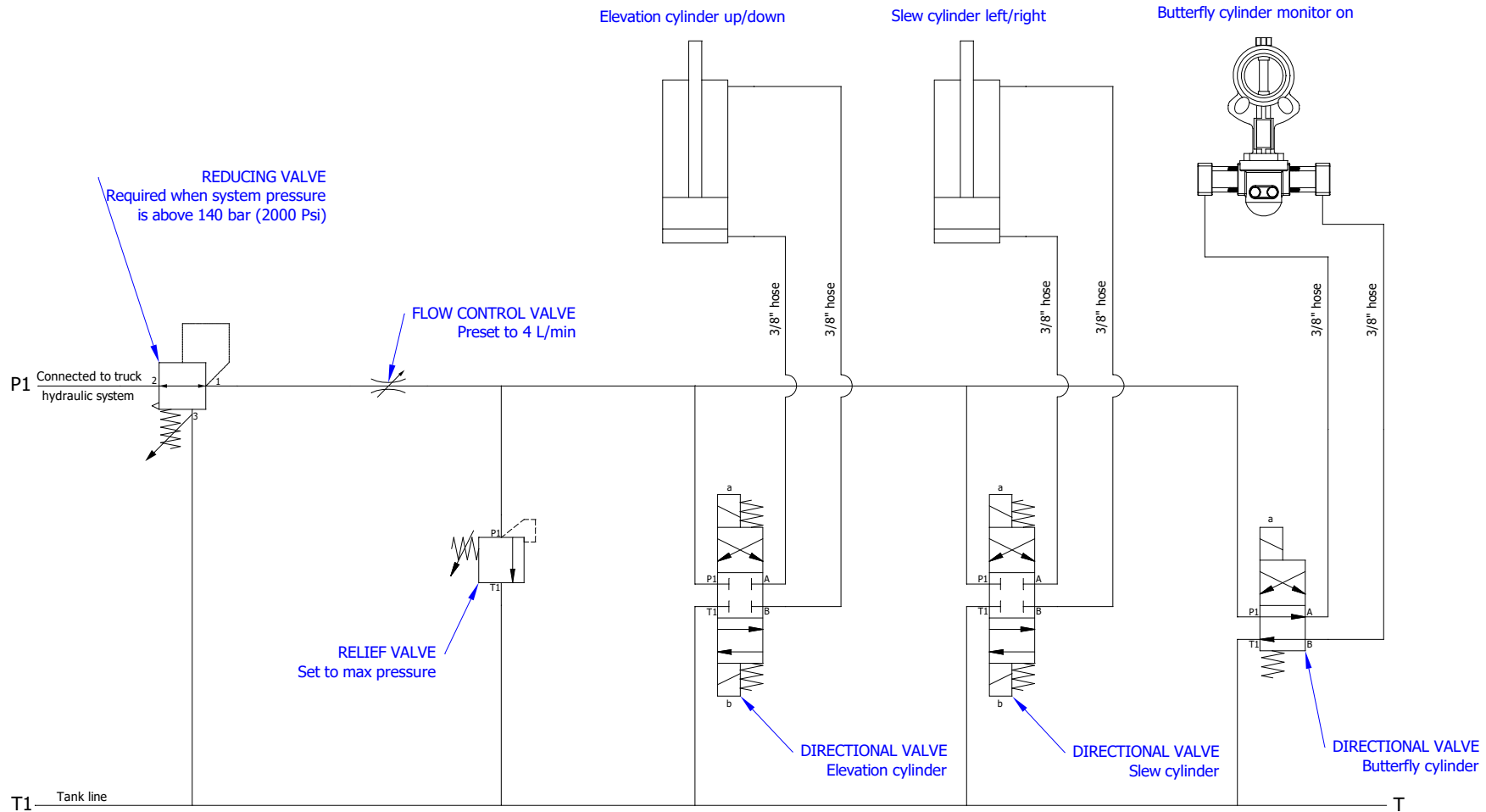

NOTES:
All ports on the manifold are 3/8" BSPP to fit 3/8" hoses
Tank line should be connected directly to the tank by a minimum of 1/2" hose

CONTRACT:

LOCATION:

+L1

Main electrical closet

RM50-H
HYDRAULIC SCHEMATIC (HDY BUTTERFLY)
STANDARD NOZZLE

				REVISION
				0
0	15/12/2020	AlbertoC		SCHEME
REV.	DATE	NAME	CHANGES	03
User data 1			User data 2	

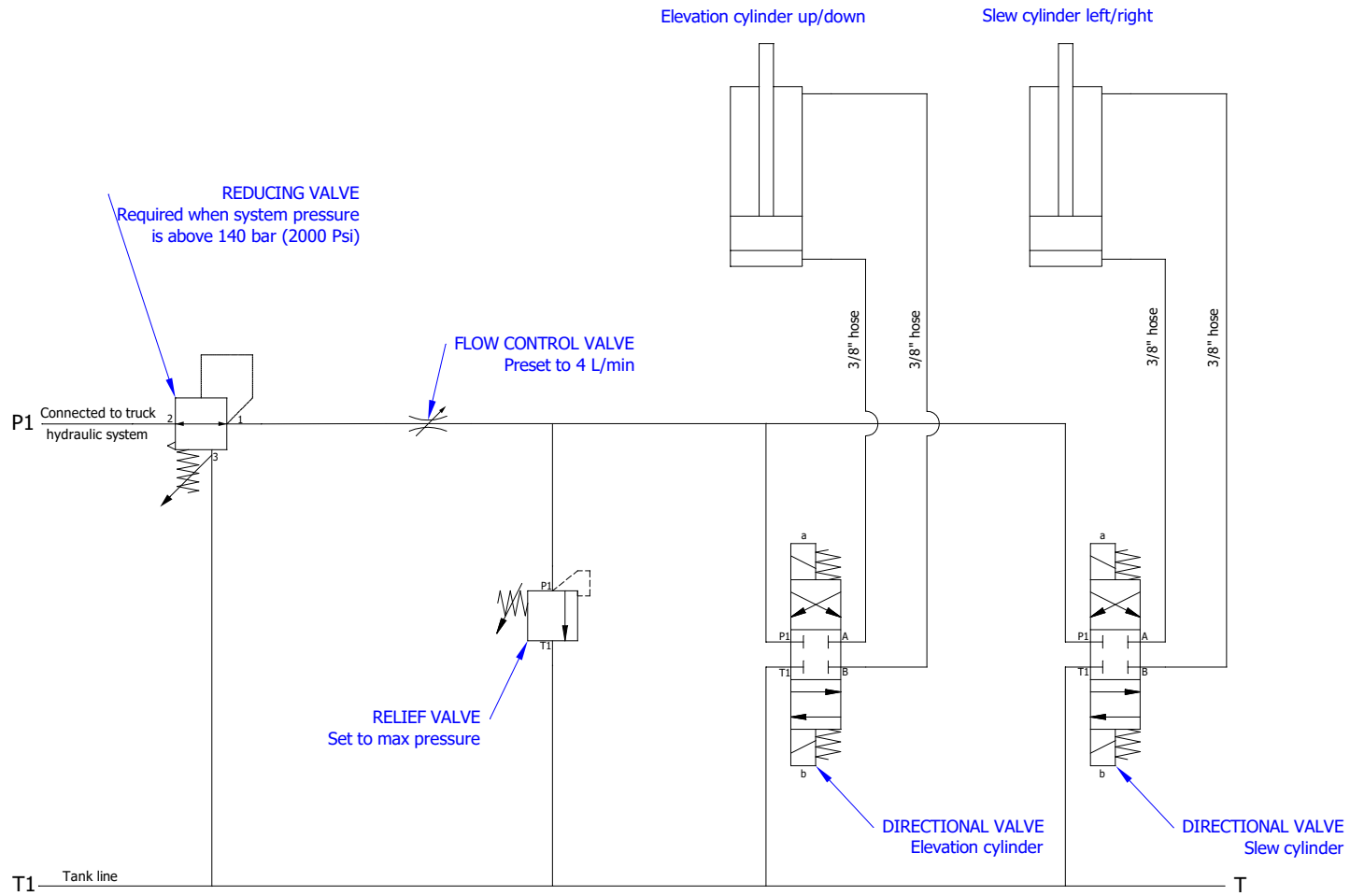

NOTES:
 All ports on the manifold are 3/8" BSPP to fit 3/8" hoses
 Tank line should be connected directly to the tank by a minimum of 1/2" hose

CONTRACT:

RM50-H
HYDRAULIC SCHEMATIC (AIR BUTTERFLY)
STANDARD NOZZLE

LOCATION: **+L1** Main electrical closet

REV.	DATE	NAME	CHANGES
0	15/12/2020	AlbertoC	
User data 1			User data 2

REVISION
0
 SCHEME
04

SOLIDWORKS Electrical



Water Cannons (hydraulic information)

It is possible to operate RM50-H at a pressure between 35 bar (500 PSI) and 140 bar (2000 PSI). The hydraulic cylinders, valves and hoses are rated at 140 bar.

RM50H must not be run above 40 bar (600 PSI). The drive gears used on the slew drive of the RM50H has a limited torque capability.

Needle valves are fitted to control the overall operating speed of a water cannon movement – left / right / up / down. These valves are fitted directly to the operating hydraulic cylinder / hydraulic motor of the water cannon. The needle valve is fitted to control the finite orifice size of the oil inlet – a smaller orifice = less flow = slower speed of movement.

1 Hydraulic Supply is tapped out of an existing system.

- The pressure must be limited to 35 bar (500 PSI) (See note above).
- Pressure control by a pressure reducing / relieving valve is required if the pressure in the system is going to be above 40 bar.
- Pressure compensated flow control valve is always required to be installed into the system.
- Recommended hose size is 3/8" or larger.
- The tank line from the hydraulic control manifold MUST be piped directly back to the system oil tank separately from the return line of the system. Failure to correctly plumb the return oil hydraulic system MAY result in incorrect operation of the system.

2 Hydraulic Supply is taken from a powerpack supplied by Magnum.

- It is possible to run 1 powerpack with RM50-H and double acting spray valves. Two separate powerpacks will be required if you run double acting spray valves. The reason for this; RM50-H and double acting spray valves can both run at 140 bar (2000 PSI). RM50H is required to run at a maximum pressure of 40 bar and double acting spray valves will require pressure greater than 40 bar. Pressure up to 140 bar may be needed to close the double acting spray valves under certain operating conditions.
- Pressure control will be by means of the relief valve on the powerpack. The relief valve is located inside the oil reservoir.
- Recommended hose size is 3/8" or larger."
- The Tank line from the hydraulic control manifold MUST be piped directly back to the system oil tank separately from the return line of the system. Failure to correctly plumb the return oil hydraulic system MAY result in incorrect operation of the system.



Water Cannon (hydraulic information)

Standard Nozzle Manifold (Hydraulic Butterfly)

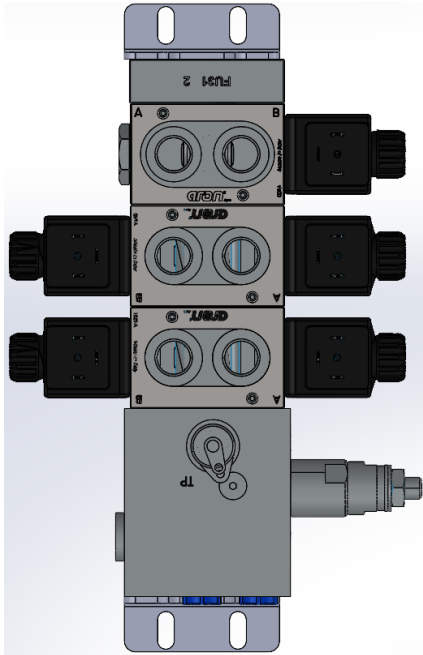

Standard Nozzle Manifold (Air Butterfly)

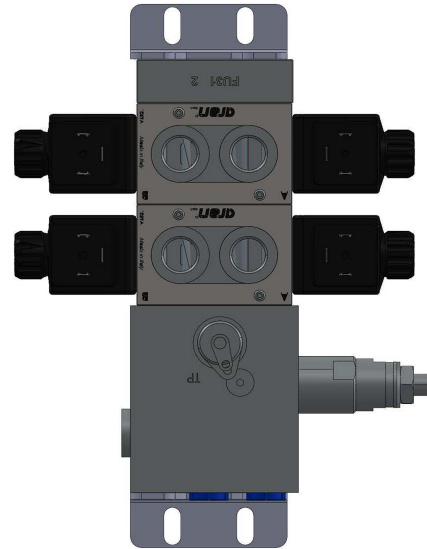

- Double solenoid valves are used on cannon functions and the single solenoid are used to open the butterfly valve.
- It is important when support is required from Magnum that we are supplied with all the part numbers between A & B.
- Magnum uses parallel and series valves. Valves are identified by the part number stamped between the A & B on the valve label. Generally, series valves would be used on a powerpack system and all other systems would use parallel valves. Parallel and series valves must not be used on the same assembly.
- Magnum uses single and double acting valves with 1 or 2 solenoids on them.
- All ports on the manifold assembly are 3/8" BSPP. It is important that the correct parallel fittings are used in the valve ports. If tapered fittings are used, it is possible to distort the valve body resulting in the spool jamming and the valve not working. Part numbers for adapters that suit this style of ports are Ryco S74-0609, Parker Triple-Lok 6-6F40MX-S, Aeroquip GG106-NP0606 or equivalents.
- All valves come standard with manual override. These are located in the centre of the tube holding the solenoid to the valve. It is needed an Allen Key or small star screwdriver in order to operate the valve using the manual override. If a function happens using the manual override and it does not happen with the solenoid, it is quite safe to assume that the coil has failed. Electrical coils are easily tested by a person with electrical knowledge using a multi-meter.
- Contamination can jam a valve. If there is a need to strip and clean a valve, cleanliness is most important. It is recommended that the parts from a valve are cleaned using a suitable solvent and those parts are dried using compressed air. No cloth should be used to dry the valve. The valve should be assembled using clean hydraulic fluid.
- It is important that a torque wrench is used to tighten the tie rods when a manifold bank is assembled. The tightening torque to be used is 5 Nm (44 inch lbs). Over tightening the tie rods will result in the valves jamming and failing to operate.



7. Electric Schematic & Electrical Information

12 PIN DEUSTCH PLUG

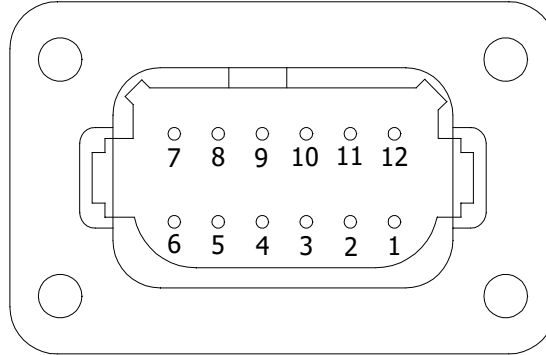

OUTPUTS

- Pin 1 Power <+>
- Pin 2 Cannon - Slew Left
- Pin 3 Cannon - Slew Right
- Pin 4 Cannon - Elevation Up
- Pin 5 Cannon - Elevation Down
- Pin 6 Fog (Optional)
- Pin 7 Jet (Optional)
- Pin 8 Monitor Open
- Pin 9 Foam
- Pin 10 Auxiliary
- Pin 11 Auxiliary
- Pin 12 Earth (Yellow / Green)

SOLIDWORKS Electrical

NOTES:
 1. The water cannon is controlled through the Deutsch plug.
 2. View is looking onto the plug. The wires from the control box are connected to the back of the plug.

CONTRACT:

RM50-H	
12 PIN DEUTSCH PLUG CONNECTION	
LOCATION:	+L1 Main electrical closet

				REVISION
				0
REV.	DATE	NAME	CHANGES	SCHEME
0	15/12/2020	AlbertoC		05
User data 1			User data 2	

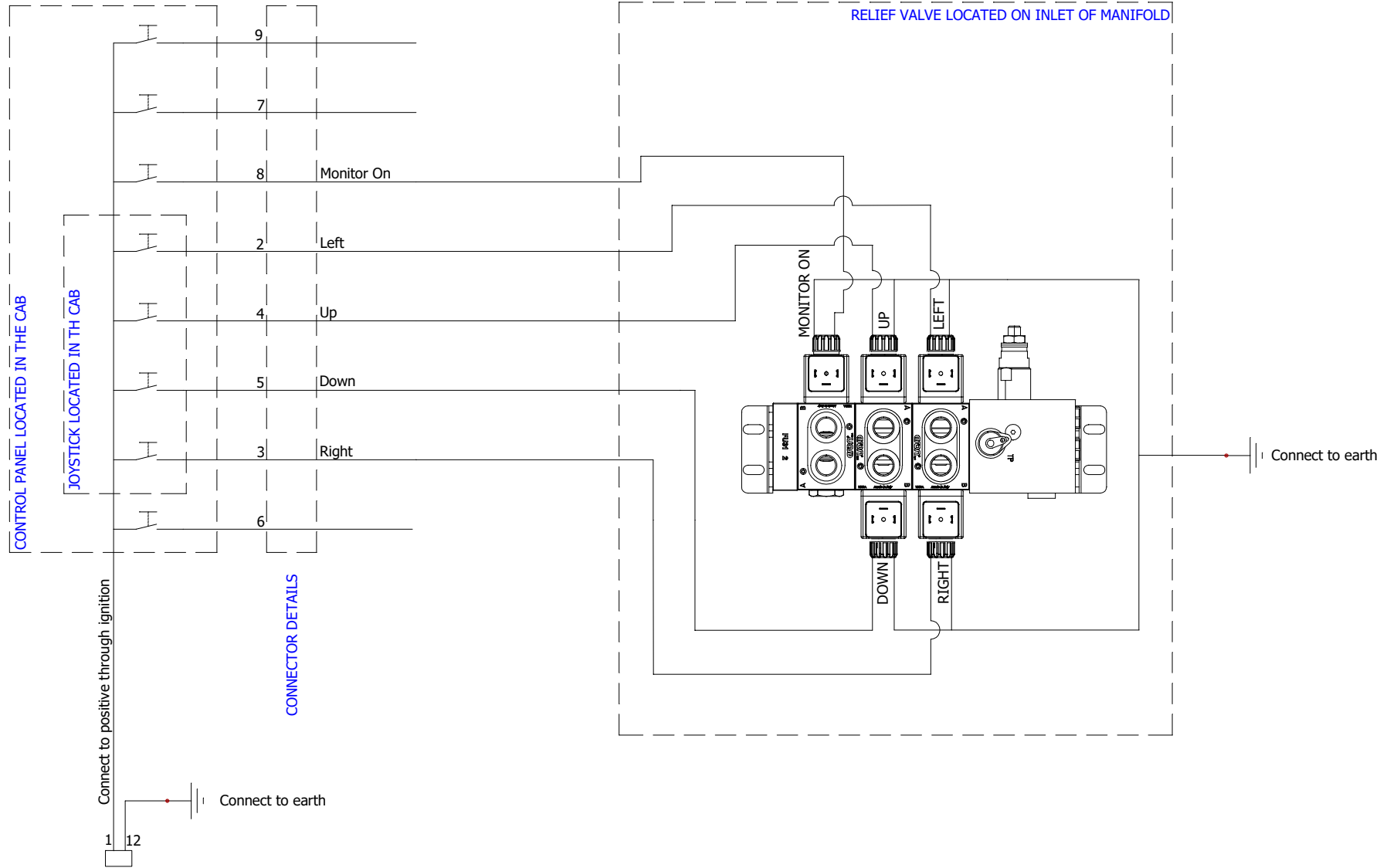

12 core cable between cab and hydraulic valves
Typically number 1 wire is connected to number 1 Pin on 12 Pin deustch connector

RM50-H
JOYSTICK CONTROL BOX (HDY BUTTERFLY)
STANDARD NOZZLE

CONTRACT:

LOCATION: **+L1** Main electrical closet

				REVISION
				0
0	15/12/2020	AlbertoC		SCHEME
REV.	DATE	NAME	CHANGES	06
User data 1			User data 2	

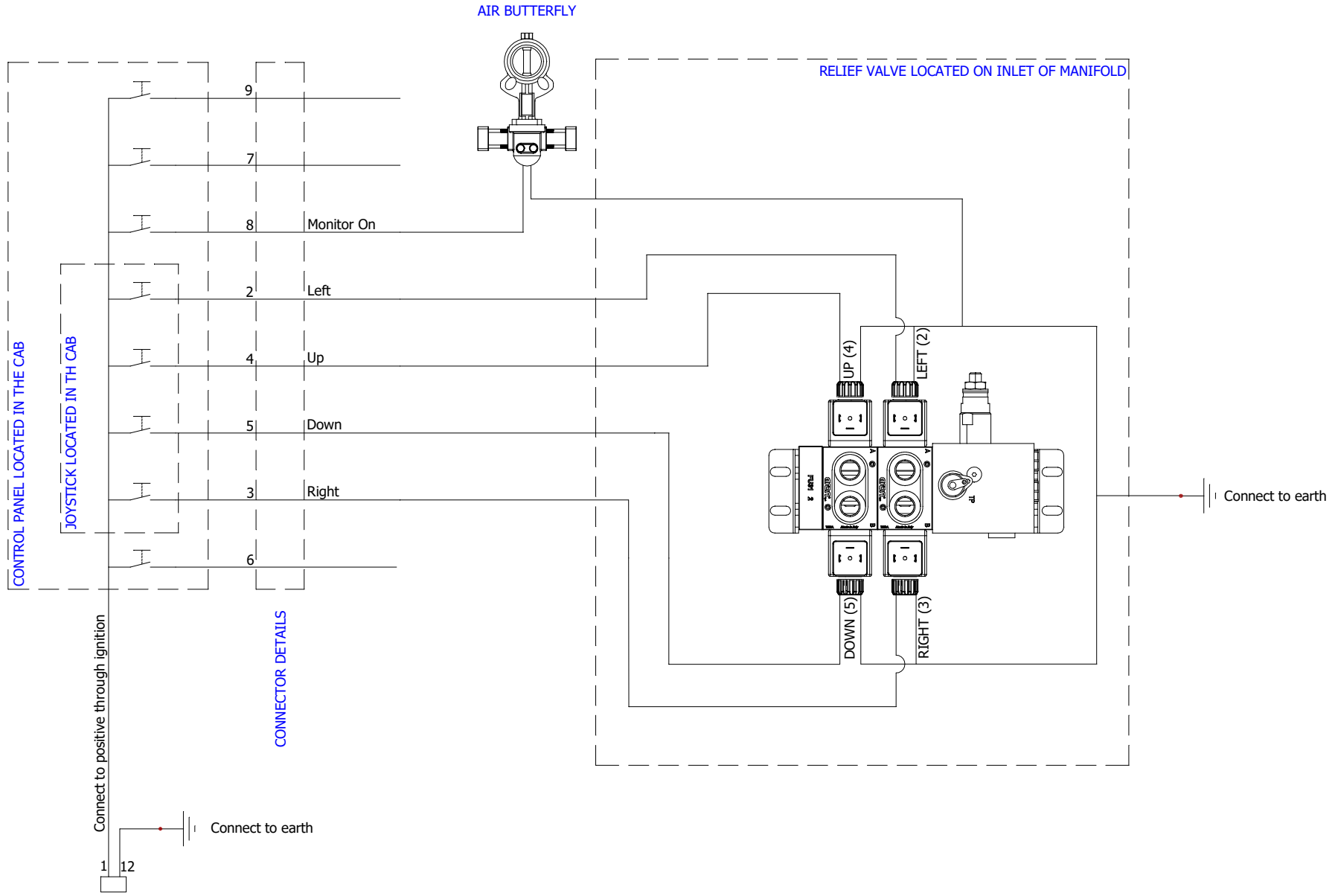

12 core cable between cab and hydraulic valves
Typically number 1 wire is connected to number 1 Pin on 12 Pin deustch connector

RM50-H
JOYSTICK CONTROL BOX (AIR BUTTERFLY)
STANDARD NOZZLE

CONTRACT:

LOCATION: **+L1** Main electrical closet

REV.	DATE	NAME	CHANGES
0	15/12/2020	AlbertoC	
User data 1			User data 2

REVISION	0
SCHEME	07

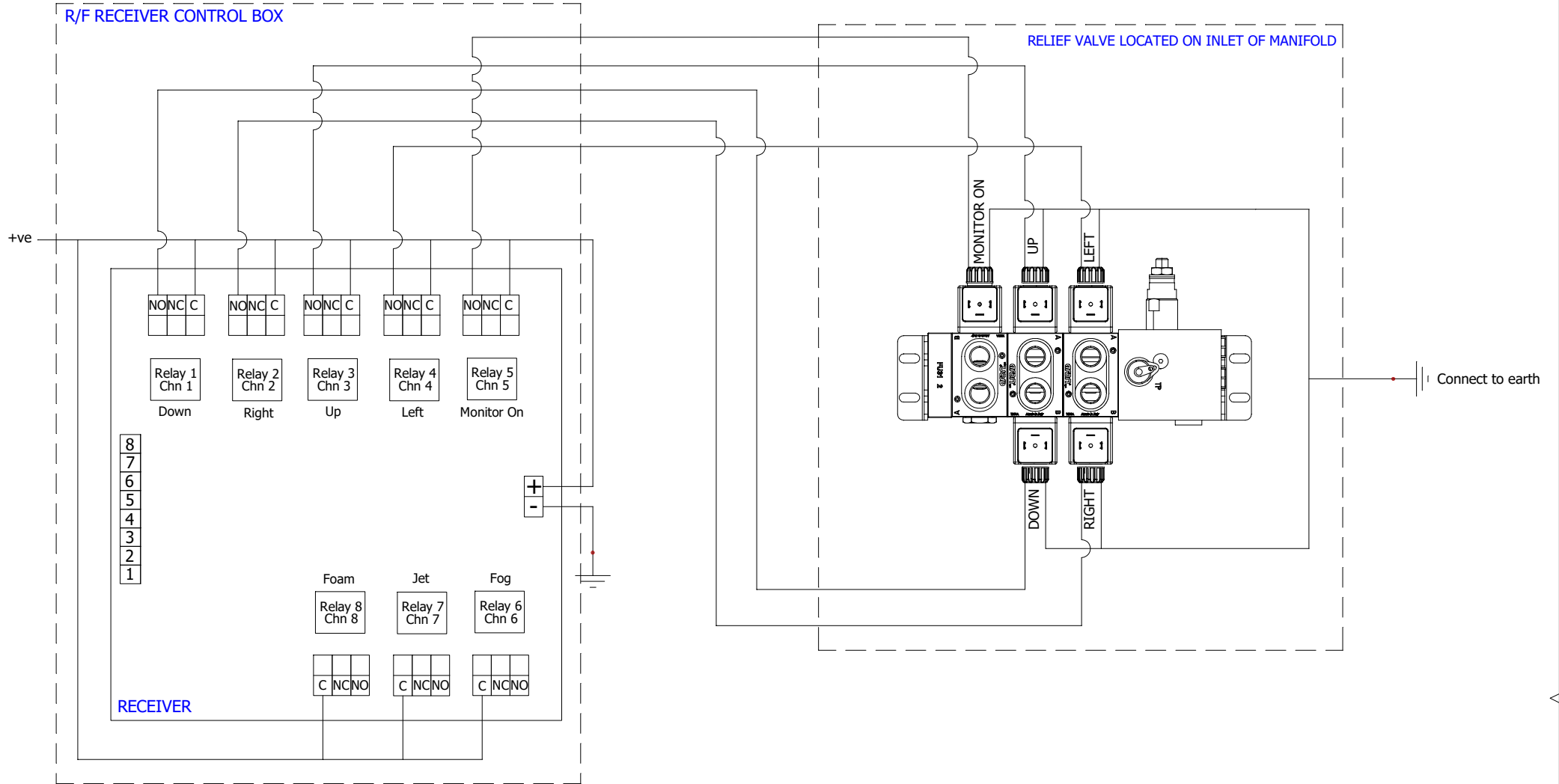

CONTRACT:	LOCATION: +L1	Main electrical closet	RM50-H		REVISION		
			RF CONTROL (HDY BUTTERFLY)		0		
			STANDARD NOZZLE		SCHEME		
			REV.	DATE	NAME	CHANGES	08
			User data 1		User data 2		

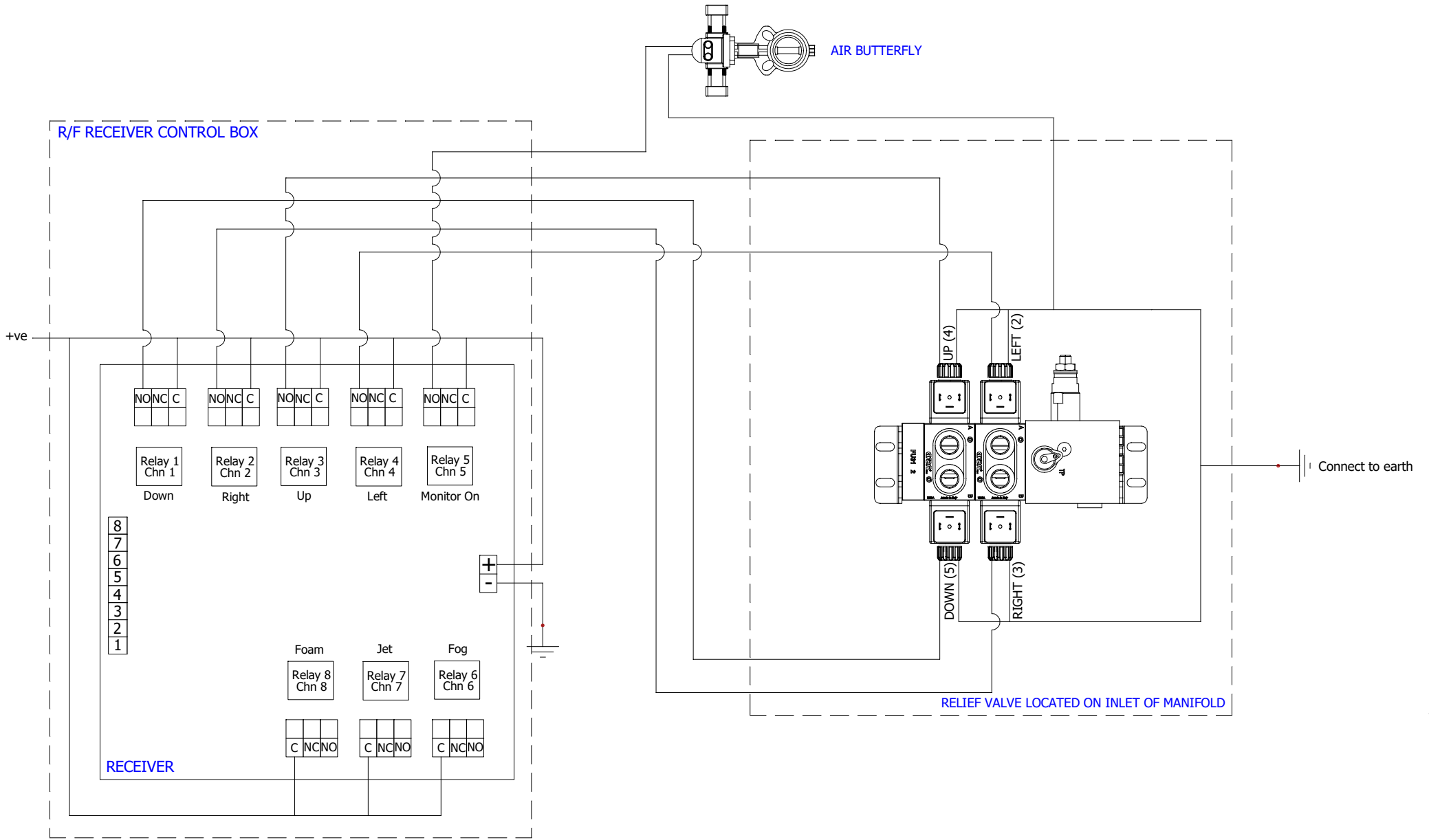

RM50-H
RF CONTROL (AIR BUTTERFLY)
STANDARD NOZZLE

CONTRACT:

LOCATION:

+L1

Main electrical closet

				REVISION
				0
0	16/12/2020	AlbertoC		
REV.	DATE	NAME	CHANGES	SCHEME
				09
User data 1			User data 2	



Date: 16 December 2020

Revision:

Created: Alberto Ceron (Engineer)

Checked: Rocky Di Battista (Operations Manager)

Approved: Sean Haviland (Director)