



Hydraulic Water Cannon RM65-H-360-C

Index

1. Water Cannon - Warning - Hazard to Health	P.2
2. RM65-H-360-C Brochure	P.
3. Outline Drawing of Cannon (Exploded View / Spare Parts)	P.
4. Installation Instructions	P.
5. Maintenance Schedule	P.
6. Hydraulic Schematic & Hydraulic Information	P.
7. Electric Schematic & Electrical Information	P.



1. Water Cannon - Warning - Hazard to Health

Care needs to be taken operating a water cannon. Water from a cannon is capable of inflicting serious injury to a person in the path of the jet.

Primary injuries would be those from the direct hit to the body by the impact of the jet. These would include bruising of internal organs and damage to the eyes.

Secondary injuries can occur as a result of the acceleration of the body in collision with hard surfaces. These injuries would be largely skeletal, such as broken bone. Other injuries could be caused by debris, accelerated by the force of the water jet striking the person.

The following should be considered as a minimum level of care required when operating a water cannon:

- Know the direction that the cannon is aiming at. Aim the cannon in a safe direction before turning the water on.
- Keep all personal out of the front of the cannon. Dangerous flow velocities can cause serious injury for quite a distance in front of the cannon.
- The cannon contain moving parts. Keep hands, fingers, and objects away from pinch points when working close to the cannon.
- Do not attempt to modify the equipment in any way. Modifications of the equipment may result in damage and/or malfunction of the equipment which could cause injury to the operator or other. Also, the manufacturer's warranty will be void.
- Follow all the maintenance procedures in the documentation. Failure to do so, can result in damage and/or malfunction of the equipment which could cause injury to the operator or other.



2. RM65-H-360-C Brochure



- Hydraulic driven slew and elevation
- 70° Elevation (as standard) (45° above horizontal, 25° below horizontal)
- Automatic grease lubrication
- Up to 350° slew (maximum)
- 12v or 24v available
- Electric 4-way Joystick controller supplied
- Optional radio frequency (R.F) wireless control available
- 65mm (2 1/2") ANSI 150lb flanged inlet connection
- Unit preset to correct settings and tested prior to final packaging and dispatch
- Director nozzle supplied as standard; 28mm (1 1/8") orifice and 60 m water throw at 7 bar
- Mounting flange with fasteners included option of air or electric to turn water on/off
- Optional remote foam/fog nozzle available operated by electrics

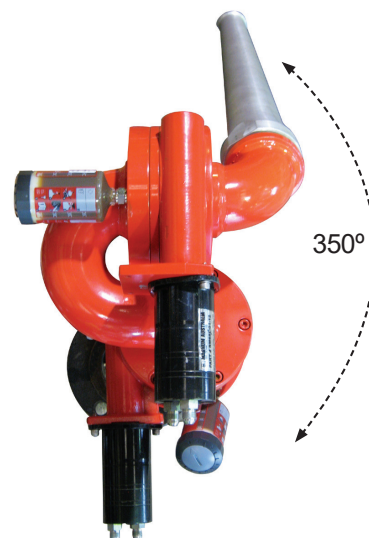
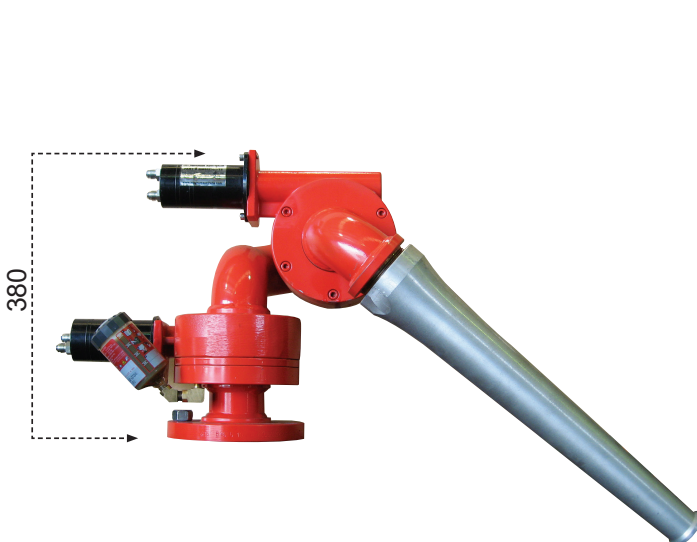



3. Outline Drawing of Cannon & Exploded View / Spare Parts



UNLESS OTHERWISE SPECIFIED DIMENSIONS ARE IN MILLIMETERS SURFACE FINISH: PAINT:		TOLERANCES UNLESS NOTED WHOLE DIMENSIONS ±0.50 ONE DECIMAL PLACE ±0.25 TWO DECIMAL PLACES ±0.10 ANGLES ±0.30°		DO NOT SCALE DRAWING	DEBURR AND BREAK SHARP EDGES	
				 MAGNUM AUSTRALIA <small>35 PARKHURST DRIVE KNOXFELD, VICTORIA 3180 PHONE 98018433</small>		
	NAME	SIGNATURE	DATE	REVISION	TITLE:	
DRAWN	Alberto C		18/09/2020		WATER CANNON RM65-H-360C	
CHECKED						
APPROVED						
					DWG NO.	
			MATERIAL: N/A		RM65-H-360C	A3
			THICKNESS:		SCALE: 1:4	SHEET 1 OF 7

8 | 7 | 6 | 5 | 4 | 3 | 2 | 1

F
E
D
C
B
A

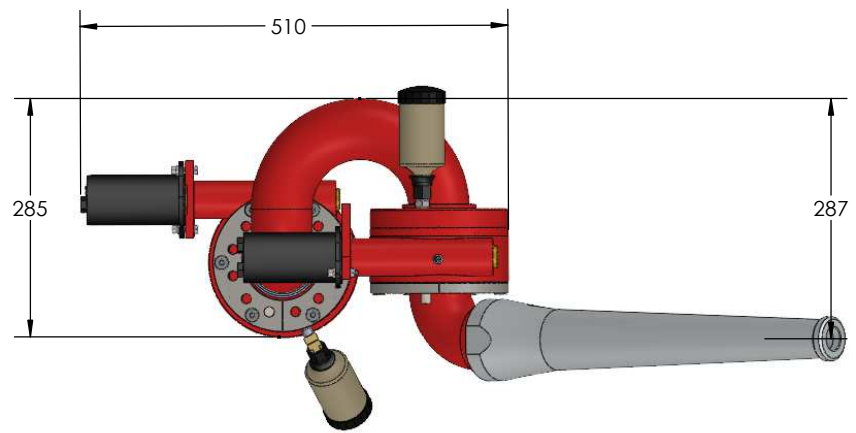
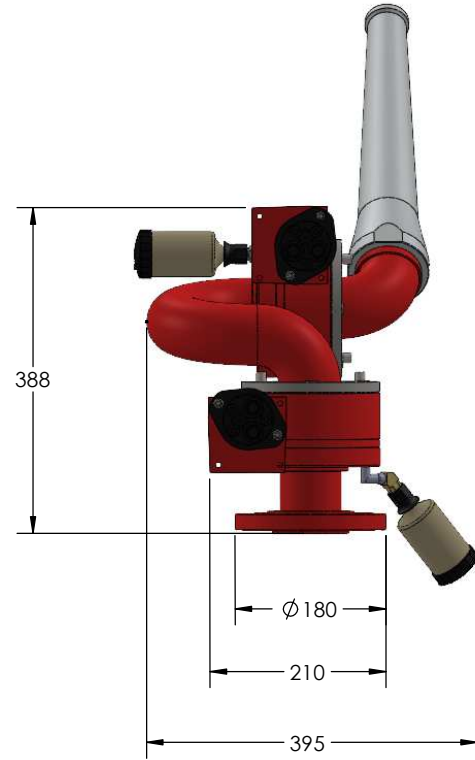
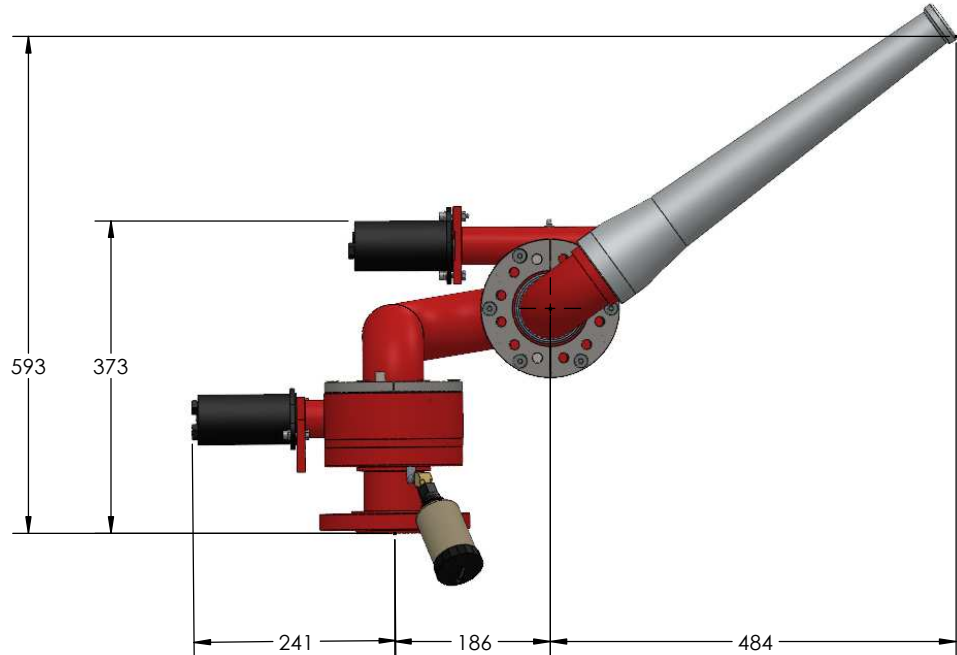

8 | 7 | 6 | 5 | 4 | 3 | 2 | 1

F
E
D
C
B
A

UNLESS OTHERWISE SPECIFIED DIMENSIONS ARE IN MILLIMETERS		TOLERANCES UNLESS NOTED WHOLE DIMENSIONS ±0.50 ONE DECIMAL PLACE ±0.25 TWO DECIMAL PLACES ±0.10 ANGLES ±0.30°		DO NOT SCALE DRAWING	DEBURR AND BREAK SHARP EDGES	
SURFACE FINISH:		PAINT:		 MAGNUM AUSTRALIA <small>35 PARKHURST DRIVE KNOXFIELD, VICTORIA 3180 PHONE 98018433</small>		
DRAWN	NAME	SIGNATURE	DATE	REVISION	TITLE:	
CHECKED	Alberto C		18/09/2020		WATER CANNON RM65-H-360C	
APPROVED						
					DWG NO.	
					RM65-H-360C	A3
					MATERIAL:	
					N/A	
					THICKNESS:	
					SCALE: 1:6	SHEET 2 OF 7

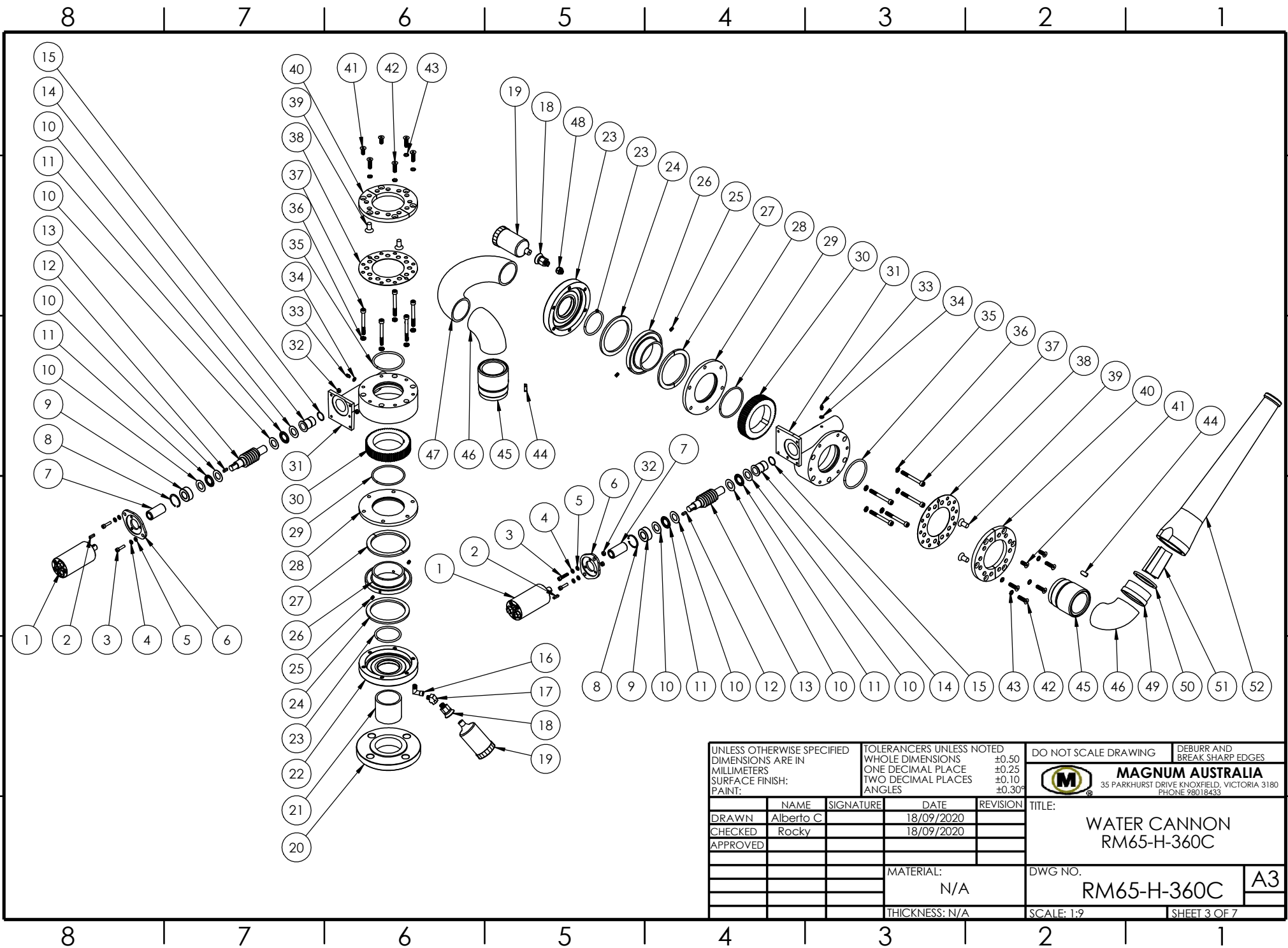

UNLESS OTHERWISE SPECIFIED DIMENSIONS ARE IN MILLIMETERS SURFACE FINISH: PAINT:		TOLERANCERS UNLESS NOTED WHOLE DIMENSIONS ±0.50 ONE DECIMAL PLACE ±0.25 TWO DECIMAL PLACES ±0.10 ANGLES ±0.30°		DO NOT SCALE DRAWING		DEBURR AND BREAK SHARP EDGES	
				M		MAGNUM AUSTRALIA 35 PARKHURST DRIVE KNOXFELD, VICTORIA 3180 PHONE 98018433	
	NAME	SIGNATURE	DATE	REVISION	TITLE:		
DRAWN	Alberto C		18/09/2020		WATER CANNON RM65-H-360C		
CHECKED	Rocky		18/09/2020				
APPROVED							
					MATERIAL:		DWG NO.
					N/A		RM65-H-360C
					THICKNESS: N/A		A3
					SCALE: 1:9		SHEET 3 OF 7

8 | 7 | 6 | 5 | 4 | 3 | 2 | 1

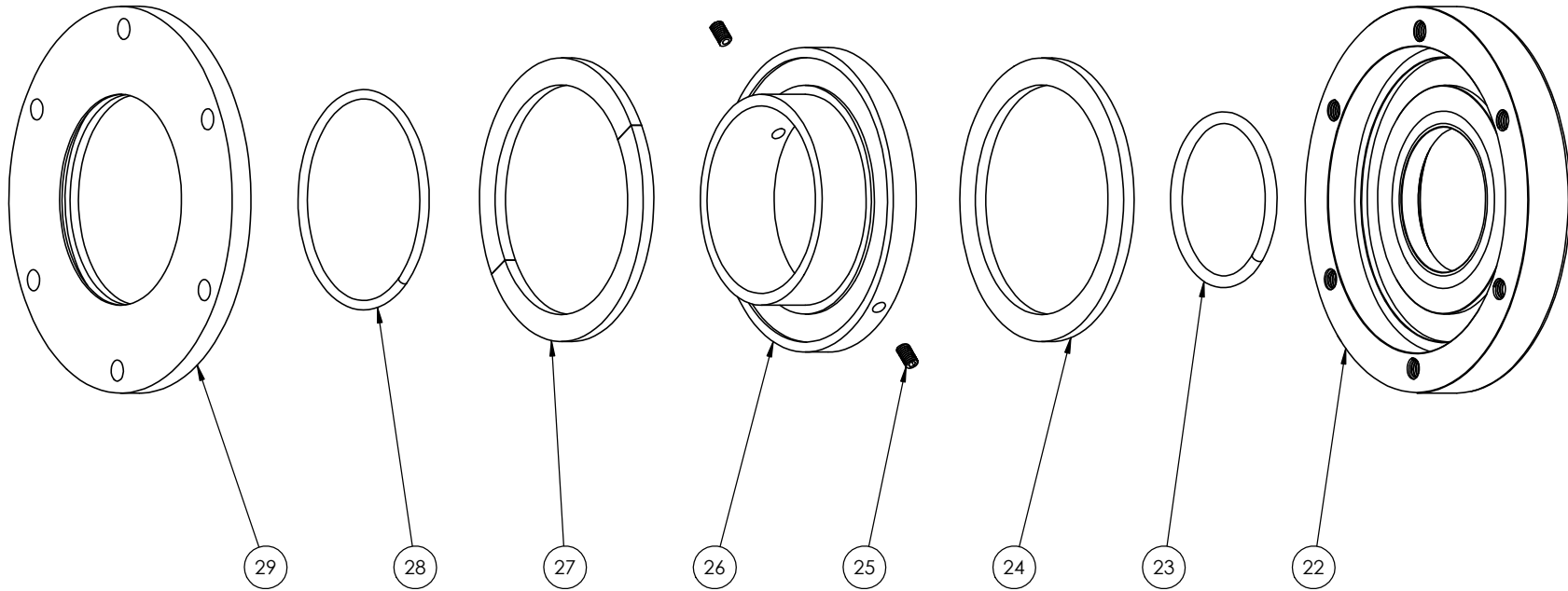

FOR CUSTOMER INFORMATION

ITEM NO.	PART NUMBER	DESCRIPTION	QTY.
22-23-24-25-26-27-28-29	BM0805-LP	COMPLETE BEARING FOR RM65-H-360C	2
23-24-27-28	WB-RK2-LP	BEARING RECONDITIONING KIT FOR RM65-H-360C	2

UNLESS OTHERWISE SPECIFIED DIMENSIONS ARE IN MILLIMETERS		TOLERANCERS UNLESS NOTED WHOLE DIMENSIONS ±0.50 ONE DECIMAL PLACE ±0.25 TWO DECIMAL PLACES ±0.10 ANGLES ±0.30°		DO NOT SCALE DRAWING		DEBURR AND BREAK SHARP EDGES	
SURFACE FINISH:		PAINT:		 MAGNUM AUSTRALIA 35 PARKHURST DRIVE KNOXFIELD, VICTORIA 3180 PHONE 98018433		TITLE: COMPLETE BEARING FOR RM65-H-360C	
DRAWN	Alberto C	SIGNATURE	DATE				
CHECKED	Rocky		18/09/2020				
APPROVED							
		MATERIAL:		DWG NO.		BM0805-LP	
		N/A					
		THICKNESS: N/A		SCALE: 1:2		SHEET 4 OF 7	

8 | 7 | 6 | 5 | 4 | 3 | 2 | 1

8 | 7 | 6 | 5 | 4 | 3 | 2 | 1

F

F

E

E

D

D

C

C

B

B

A

A

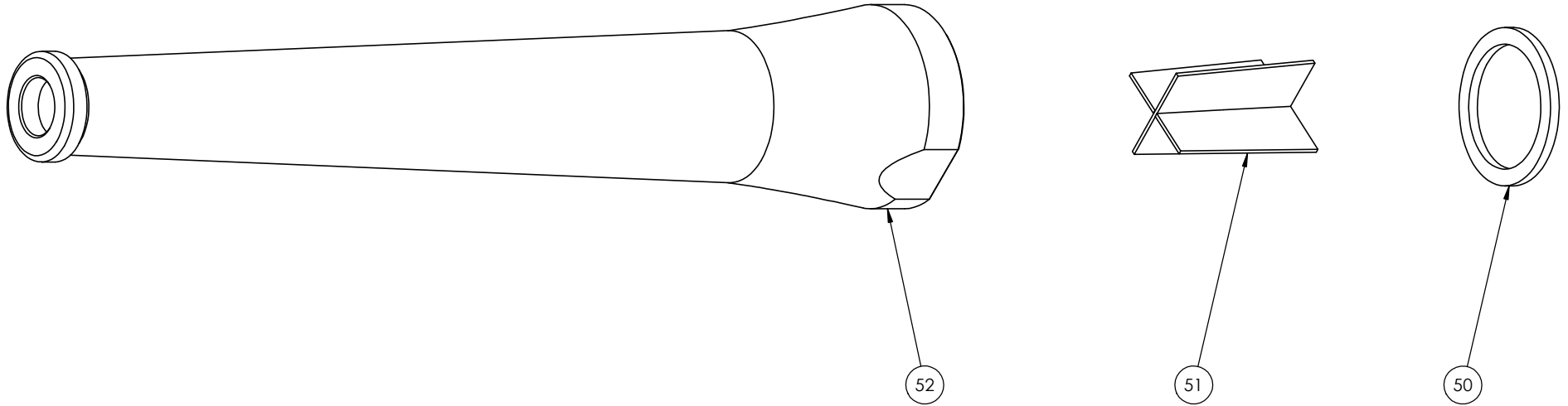

FOR CUSTOMER INFORMATION

ITEM NO.	PART NUMBER	DESCRIPTION	QTY.
50-51-52	BM0015-AS	NOZZLE KIT FOR RM65-H-360C	1

UNLESS OTHERWISE SPECIFIED DIMENSIONS ARE IN MILLIMETERS		TOLERANCERS UNLESS NOTED WHOLE DIMENSIONS ±0.50 ONE DECIMAL PLACE ±0.25 TWO DECIMAL PLACES ±0.10 ANGLES ±0.30°		DO NOT SCALE DRAWING	DEBURR AND BREAK SHARP EDGES
SURFACE FINISH: PAINT:				 MAGNUM AUSTRALIA <small>35 PARKHURST DRIVE KNOXFELD, VICTORIA 3180 PHONE 98018433</small>	
	NAME	SIGNATURE	DATE	REVISION	TITLE:
DRAWN	Alberto C		18/09/2020		NOZZLE KIT FOR RM65-H-360C
CHECKED	Rocky		18/09/2020		
APPROVED					
					DWG NO. BM0015-AS
					A3
					THICKNESS: N/A
					SCALE: 1:2
					SHEET 5 OF 7

8 | 7 | 6 | 5 | 4 | 3 | 2 | 1

8 7 6 5 4 3 2 1

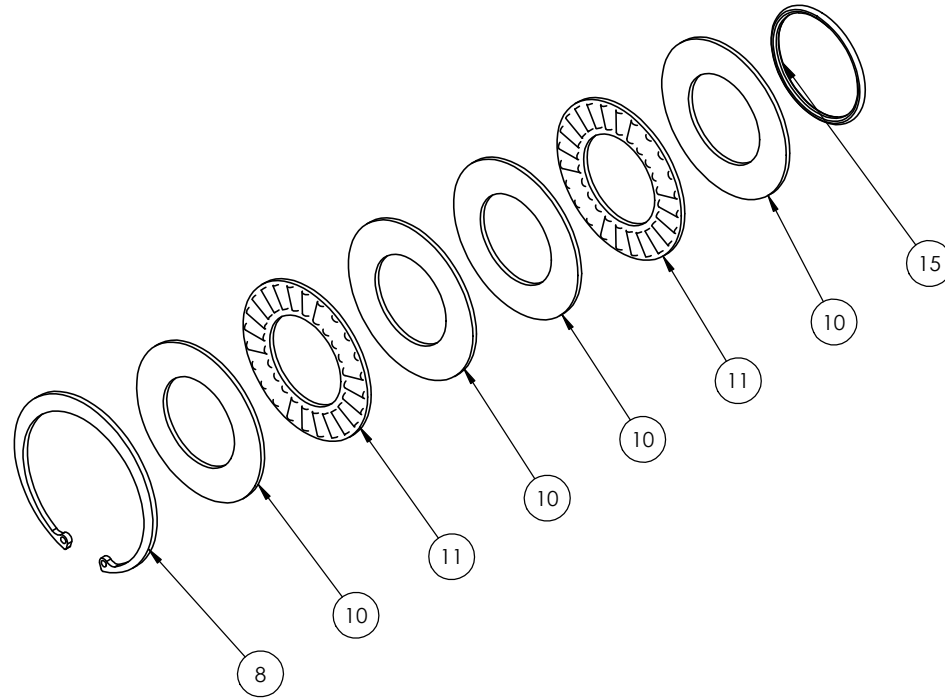

FOR CUSTOMER INFORMATION

ITEM NO.	PART NUMBER	DESCRIPTION	QTY.
8-10-11-15	MAG-WDSKIT	WORM DRIVE SEAL KIT	2

UNLESS OTHERWISE SPECIFIED DIMENSIONS ARE IN MILLIMETERS		TOLERANCES UNLESS NOTED WHOLE DIMENSIONS ±0.50 ONE DECIMAL PLACE ±0.25 TWO DECIMAL PLACES ±0.10 ANGLES ±0.30°		DO NOT SCALE DRAWING	DEBURR AND BREAK SHARP EDGES	
SURFACE FINISH:		PAINT:		 MAGNUM AUSTRALIA <small>35 PARKHURST DRIVE KNOXFELD, VICTORIA 3180 PHONE 98018433</small>		
	NAME	SIGNATURE	DATE	REVISION	TITLE:	
DRAWN	Alberto C		18/09/2020		WORM DRIVE SEAL KIT	
CHECKED	Rocky		18/09/2020			
APPROVED						
					DWG NO.	
					MAG-WDSKIT	A3
					MATERIAL:	
					N/A	
					THICKNESS: N/A	
					SCALE: 1:1	SHEET 6 OF 7

8 7 6 5 4 3 2 1

8 | 7 | 6 | 5 | 4 | 3 | 2 | 1

ITEM NO.	PART NUMBER	DESCRIPTION	QTY.	ITEM NO.	PART NUMBER	DESCRIPTION	QTY.
1	MAG-151G0033	HYDRAULIC MOTOR RM65-H-360-C	2	29	WBR70-90X4	O-RING 90X4 (TOP RACE)	2
2	N/A	COMES WITH HYDRAULIC MOTOR (ITEM 1)	2	30	MAG-W-04	MAGNUM GEAR	2
3	M6-HB-25	M6 HEX BOLT 25	4	31	LLC-15-11-H	BEARING HOUSE	2
4	M6-SW	M6 SPRING SCREW WASHER	4	32	M6-NYLOCKS	M6 NYLOCK NUTS	4
5	M6-FW	M6 FLAT WASHER	4	33	NIP01	L161 M6 GREASE NIPPLE	2
6	MAG-15190211	FLANGE FOR HYDRAULIC MOTOR	2	34	M6FW	M6X12X1.2 GREASE NIPPLE WASHER	2
7	RM65C-005-E	DRIVE COUPLING	2	35	WBR70-84X5	O-RING 84X5 (BEARING HOUSING)	2
8	CIRC-001	CIRCLIP WORM GEAR	2	36	M8X13-TSWS	M8X13X1 HOUSING BOLT WASHER	10
9	LLC-15-19	LOCATING BRASS BUSH	2	37	M8X70-CSK-SH	M8X70X1.25 HOUSING BOLT	10
10	MAG-AS2035	THRUST BEARING WASHER	8	38	RM360-N-SL	GRIP SAND PAPER	4
11	MAG-AXK2035	THRUST BEARING	4	39	LLC-15-21	MECHANICAL STOP PLATE PIN	4
12	WKW-01	WORM KEY WAY	2	40	LLC-15-20	MECHANICAL STOP PLATE	4
13	MAG-W-03	WORM	2	41	M8X20-CSK-FLAT	M8X20X1 STOP PLATE SCREW	4
14	LLC-15-19-C	SHAFT END CAP	2	42	M8X30-CSK-FLAT	M8X30X1 STOP PLATE SCREW	8
15	WBR70-23X1.5	O-RING 23X1.5 (SHAFT END CAP)	2	43	M8X13-ESW	M8X13X1 STOP PLATE STAR WASHER	8
16	1/8-P-2020	90° GREASE ELBOW 1/8	1	44	GKW-01	GEAR KEY WAY (INTERNAL CASING)	2
17	P-1-8451-4	45° LOWER PERMALUBLE SUPPORT FLANGE	1	45	LLC-200-65-102	BEARING INTERNAL CASING	2
18	A620PFLEX	PERMALUBLE SUPPORT FLANGE	2	46	WE65-SR	65 mm ELBOW 90°	2
19	BM0007	GREASE CAPSULE	2	47	WE65U	65 mm ELBOW 180°	1
20	PF65	65 mm ANSI FLANGE	1	48	1/8-1/4-P-2510	REDUCER UPPER PERMALUBLE	1
21	MM65-STB-65L	65 mm STUB	1	49	MM65-009	THREADED MONITOR END	1
22	MM65-002-LP	BEARING BASE (BOTTOM RACE)	2	50	BM-0015C	NOZZLE GASKET	1
23	WBR70-65X5	O-RING 65X5 (BEARING BASE)	2	51	BM-0015B	FLIGHT SET	1
24	MB65-005	VESCO RING (1 PIECE)	2	52	BM0015	2-1/2 STANDARD DIRECTOR NOZZLE	1
25	M6-BILGS	BEARING INTERNAL LOCKING GRUB SCREW	4				
26	MB65-003	BEARING (MIDDLE RACE)	2				
27	MB65-006	VESCO RING (2 PIECES)	2				
28	MB65-004	BEARING LID (TOP RACE)	2				

FOR CUSTOMER INFORMATION

ITEM NO.	PART NUMBER	DESCRIPTION	QTY.
22-23-24-25-26-27-28-29	BM0805-LP	COMPLETE BEARING FOR RM65-H-360C	2
23-24-27-28	WB-RK2-LP	BEARING RECONDITIONING KIT FOR RM65-H-360C	2
48-49-50	BM0015-AS	NOZZLE KIT FOR RM65-H-360C	1
8-10-11-15	MAG-WDSKIT	WORM DRIVE SEAL KIT	2

UNLESS OTHERWISE SPECIFIED DIMENSIONS ARE IN MILLIMETERS SURFACE FINISH: PAINT:		TOLERANCES UNLESS NOTED WHOLE DIMENSIONS ±0.50 ONE DECIMAL PLACE ±0.25 TWO DECIMAL PLACES ±0.10 ANGLES ±0.30°		DO NOT SCALE DRAWING DEBURR AND BREAK SHARP EDGES	
				 MAGNUM AUSTRALIA <small>35 PARKHURST DRIVE KNOXFIELD, VICTORIA 3180 PHONE 98018433</small>	
NAME	SIGNATURE	DATE	REVISION	TITLE:	
Alberto C		18/09/2020		WATER CANNON RM65-H-360C	
Rocky		18/09/2020			
				DWG NO.	
		MATERIAL: N/A		RM65-H-360C	
		THICKNESS: N/A		SCALE: N/A	
				SHEET 7 OF 7	

8 | 7 | 6 | 5 | 4 | 3 | 2 | 1



4. Installation Instructions

1. Weld the flange supplied in the kit to the water cannon supply pipe.
2. Mount the cannon (monitor) and water on / off valve onto the flange using bolts and nuts supplied in the kit. Stabilisers and gussets may be required to ensure that the mounting is secure and rigid. The water on /off valve should be located between the flanges of the water cannon and the mounting flange welded to supply piping. Ensure the monitor is correctly mounted so it CANNOT direct water at the cabin of the vehicle.
3. Activate the Auto Lube grease capsule located on the Monitor Bearings to 12-month grease injection setting.
4. Screw the nozzle to the threaded end of the water cannon. Director Nozzle is standard supply. Foam induction Fog Nozzle (RFIN) is available as an option.
5. Mount the Joystick Cabin Controller Box (electric) in a position that is ergonomic for operator to use.
6. Mount the hydraulic valve manifold in a desired position (external to vehicle cabin). Note: Generally mounted close to the water cannon monitor to allow for short length of hydraulic hoses between the manifold and the cannon.
7. Run the electrical cable 8 m supplied as standard (optional extension cable is available if required) from the cabin control box to the main control box. Cut the cable to the desired length and connect up the plugs.
8. Connect the cable from the Main Control Box to the hydraulic valves on the manifold. Cut the cable to the desired length allowing for neat installation of the wiring to the solenoids. Connect the electrical cables to the solenoid valves using the Hirschmann Plugs supplied and the electric schematic diagram. Ensure all plugs are properly sealed against moisture ingress.
9. Connect the power wire as per the electric schematic.
10. Ensure the hydraulic pressure reducing valve is fitted into the hydraulic system circuit (refer to the system hydraulic circuit).
11. Connect the hydraulic hoses from supply oil to hydraulic valve manifold using 3/8 hoses. See the hydraulic schematic.
12. Connect the hydraulic hoses from hydraulic valve manifold to the return on the tank. See the hydraulic schematic.
13. Connect the required hydraulic hoses as per the hydraulic schematic from the hydraulic manifold to the water cannon. 2 hoses are required for each function.
14. Your Remote Control Water Cannon is now ready for operations.
15. Turn on the vehicle power and air to the unit.
16. Check that all air fittings are correctly fitted and there are no air leaks evident.
17. Check that all hydraulic hoses and fittings are correctly installed and no hydraulic leaks are evident.
18. Check all bolts are securely tightened and no water leaks are evident.
19. Now test the unit with the water pump operating and passing water through the nozzle.
20. Monitor slew and elevation speed can be adjusted to suit your desired operating speed. The speed adjusters (hydraulic needle valves) are located on the piston end of each hydraulic cylinder fitted to the water cannon. Screw them clockwise (in) to slow the unit, or anti-clockwise (out) to increase the speed of operation.
21. A comprehensive parts book has been supplied for your service assistance.



5. Maintenance Schedule

Initial Service

1. The upper and lower bearings have been filled with Multi-Purpose EP Type Grease in the factory at the time of assembly. 4 pumps of grease from a grease gun should be sufficient if a new bearing has been installed.
2. Set the automatic lubrication canister supplied with the cannon to 12 months. This activates the lubricator.
3. Lubricate the rod ends (mounting for cylinders) using Multi-Purpose EP Type Grease. 1 pump of grease from a grease gun should be sufficient.
4. Check the operation of the water cannon; slew and elevation.

Quarterly Service

1. Check the condition of the swivel bearings by holding the pipe firmly and shaking it vigorously. There should be no play in the swivel bearing. Replace the seals and wear rings in the swivel bearings if there is any play.
2. Check the waster cannon for leaks. If there is a leak, it will occur at the swivel bearings. Replace the seals and wear rings in the swivel bearings if there is a leak on the water cannon.
3. Lubricate the rod ends (mounting for cylinders) using Multi-Purpose EP Type Grease. 1 pump of grease from a grease gun should be sufficient.
4. Check the automatic lubrication canister. The canister has been initially set up for 12 months. If the ambient temperature is above 40 degrees centigrade, the life of the canister may be reduced. Replace the canister if there is no sign of grease in it. Set the automatic lubrication canister to 12 months. This activates the lubricator.
5. Check the operation of the water cannon; slew and elevation.

Annual Service

1. Strip and inspect the swivel bearing on the cannon. Replace the wear rings and the seals.
2. Install a new automatic lubrication canister as is indicated in quarterly service.



6. Hydraulic Schematic & Hydraulic Information



Water Cannon (hydraulic information)

It is possible to operate RM65-H at a pressure between 35 bar (500 PSI) and 140 bar (2000 PSI). The hydraulic cylinders, valves, and hoses are rated at 140 bar.

Needle valves are fitted to control the overall operating speed of a water cannon movement – left / right / up / down. These valves are fitted directly to the operating hydraulic cylinder / hydraulic motor of the water cannon. The needle valve is fitted to control the finite orifice size of the oil inlet – a smaller orifice = less flow = slower speed of movement.

1 Hydraulic Supply is tapped out of an existing system.

- The pressure must be limited to 35 bar (500 PSI) (See note above).
- Pressure compensated flow control valve is always required to be installed into the system
- Recommended hose size is 3/8" or larger.
- The tank line from the hydraulic control manifold **MUST** be piped directly back to the system oil tank separately from the return line of the system. Failure to correctly plumb the return oil hydraulic system **MAY** result in incorrect operation of the system.

2 Hydraulic Supply is taken from a powerpack supplied by Magnum.

- It is possible to run 1 powerpack with RM65H and double acting spray valves. The reason for this is; RM65H and double acting spray valves can both run at 140 bar (2000 PSI). Pressure up to 140 bar may be needed to close the double acting spray valves under certain operating conditions.
- Pressure control will be by means of the relief valve on the powerpack. The relief valve is located inside the oil reservoir.
- Recommended hose size is 3/8" or larger.
- The tank line from the hydraulic control manifold **MUST** be piped directly back to the system oil tank separately from the return line of the system. Failure to correctly plumb the return oil hydraulic system **MAY** result in incorrect operation of the system.



Water Cannon (hydraulic information)

Standard Nozzle Manifold

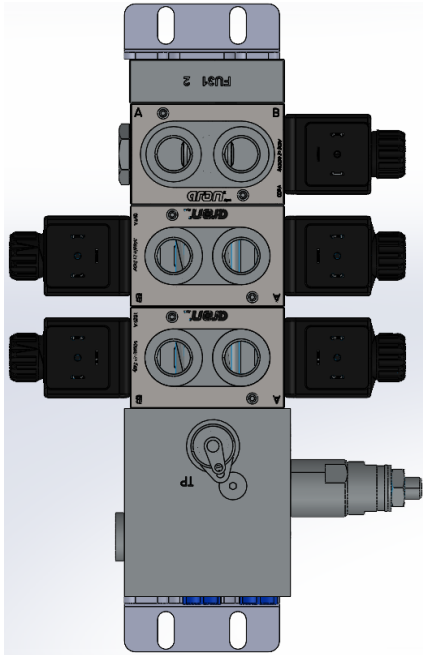

Fogjet & Foam Manifold

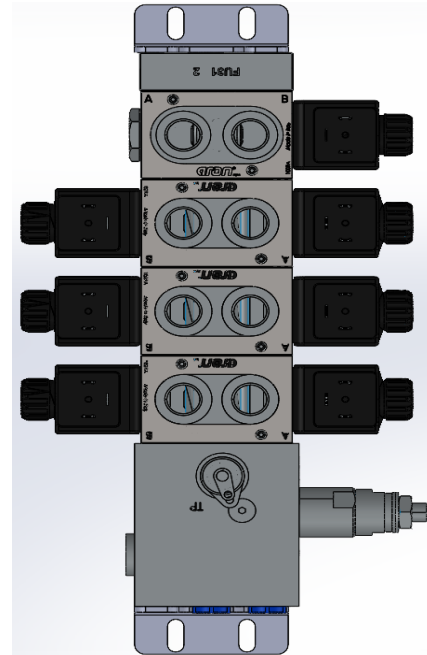

- Double solenoid valves are used on cannon functions and the single solenoid are used to open the butterfly valve.
- It is important when support is required from Magnum that we are supplied with all the part numbers between A & B.
- Magnum uses parallel and series valves. Valves are identified by the part number stamped between the A & B on the valve label. Generally, series valves would be used on a powerpack system and all other systems would use parallel valves. Parallel and series valves must not be used on the same assembly.
- Magnum uses single and double acting valves with 1 or 2 solenoids on them.
- All ports on the manifold assembly are 3/8" BSPP. It is important that the correct parallel fittings are used in the valve ports. If tapered fittings are used, it is possible to distort the valve body resulting in the spool jamming and the valve not working. Part numbers for adapters that suit this style of ports are Ryco S74-0609, Parker Triple-Lok 6-6F40MX-S, Aeroquip GG106-NP0606 or equivalents.
- All valves come standard with manual override. These are located in the centre of the tube holding the solenoid to the valve. It is needed an Allen Key or small star screwdriver in order to operate the valve using the manual override. If a function happens using the manual override and it does not happen with the solenoid, it is quite safe to assume that the coil has failed. Electrical coils are easily tested by a person with electrical knowledge using a multi-meter.
- Contamination can jam a valve. If there is a need to strip and clean a valve, cleanliness is most important. It is recommended that the parts from a valve are cleaned using a suitable solvent and those parts are dried using compressed air. No cloth should be used to dry the valve. The valve should be assembled using clean hydraulic fluid.
- It is important that a torque wrench is used to tighten the tie rods when a manifold bank is assembled. The tightening torque to be used is 5 Nm (44 inch lbs). Over tightening the tie rods will result in the valves jamming and failing to operate.



7. Electric Schematic & Electrical Information



Date: 7 December 2020

Revision:

Created: Alberto Ceron (Engineer)

Checked: Rocky Di Battista (Operations Manager)

Approved: Sean Haviland (Director)